



© Armfield Ltd. 2013
armfield

ISO 9001:2008
2YR EXTENDED WARRANTY

FEATURES

- Self-contained system
- Floor-standing
- Single extraction/desolventiser vessel
- Miscella tank
- Tops condensor
- Solvent/water recovery tank
- All flameproof construction

BENEFITS

- Operation of small-scale version of industrial processes
- A wide variety of solid/liquid extractions may be processed
- Small quantities (25kgs) can be processed
- Low waste disposal rates

ISSUE - 3



Scan to learn more



The Armfield Solvent Extraction Unit is a floor-standing, batch processing unit, capable of carrying out a variety of solid/liquid extractions. It is particularly suitable for 'leaching' edible oils from oil-bearing seeds and desolventising both the extracted solids and the miscella.

Description

All vessels, pipes, valves and fittings in contact with process materials are constructed in stainless steel with the exception of the borosilicate glass solvent condenser. The support framework is also stainless steel.

The cylindrical extractor/desolventiser with a hinged lid for charging the extraction material, has a base inclined slightly towards a port for discharging the extracted and desolventised meal. Material is supported above the base by a perforated plate covered with a fine woven mesh so solvent may drain through to the miscella tank while retaining the solids. The vessel base is equipped with an indirect steam chest for process heating.

Direct steam is injected at a variable rate through a distribution pipe positioned above the mesh. A similar distribution pipe positioned near the top of the vessel enables solvent to be sprayed uniformly onto the bed of material. The miscella tank, positioned directly below the extractor to collect the draining liquid, is also a cylindrical vessel incorporating a steam chest as its base.

This vessel also incorporates a direct steam distribution pipe through which steam can be metered at a variable rate.

Vapour from the vessels, produced in the desolventising process, is directed by ducting to the solvent condenser, an inclined cylindrical glass tube containing a double coil through which cooling water is circulated. Condensate (usually a mixture of solvent and water) drains into the solvent water separator tank, which enables thorough separation of the solvent and water by a gravity process.

(Note: Only hexane or solvents having a similar specific gravity can be effectively separated in this tank).

Solvent reclaimed from this vessel can then be recirculated by the solvent pump at a regulated rate through a variable area flow meter. Excess water overflows to a waste water tank from where it can be disposed of on completion of the process. Operation at reduced system pressures are achieved by a PTFE diaphragm type vacuum pump. The outlet of this pump is piped through a flame arrester to a suitable ventilation point.

Each vessel is equipped with suitable level/sight glasses so that the processes can be observed and monitored. Pressure and temperature gauges are supplied where necessary as are adequate sampling and drain valves.

Hexane is the most widely used solvent in the extraction process and due to the inflammable nature of this product, electrical equipment has been kept to a minimum.

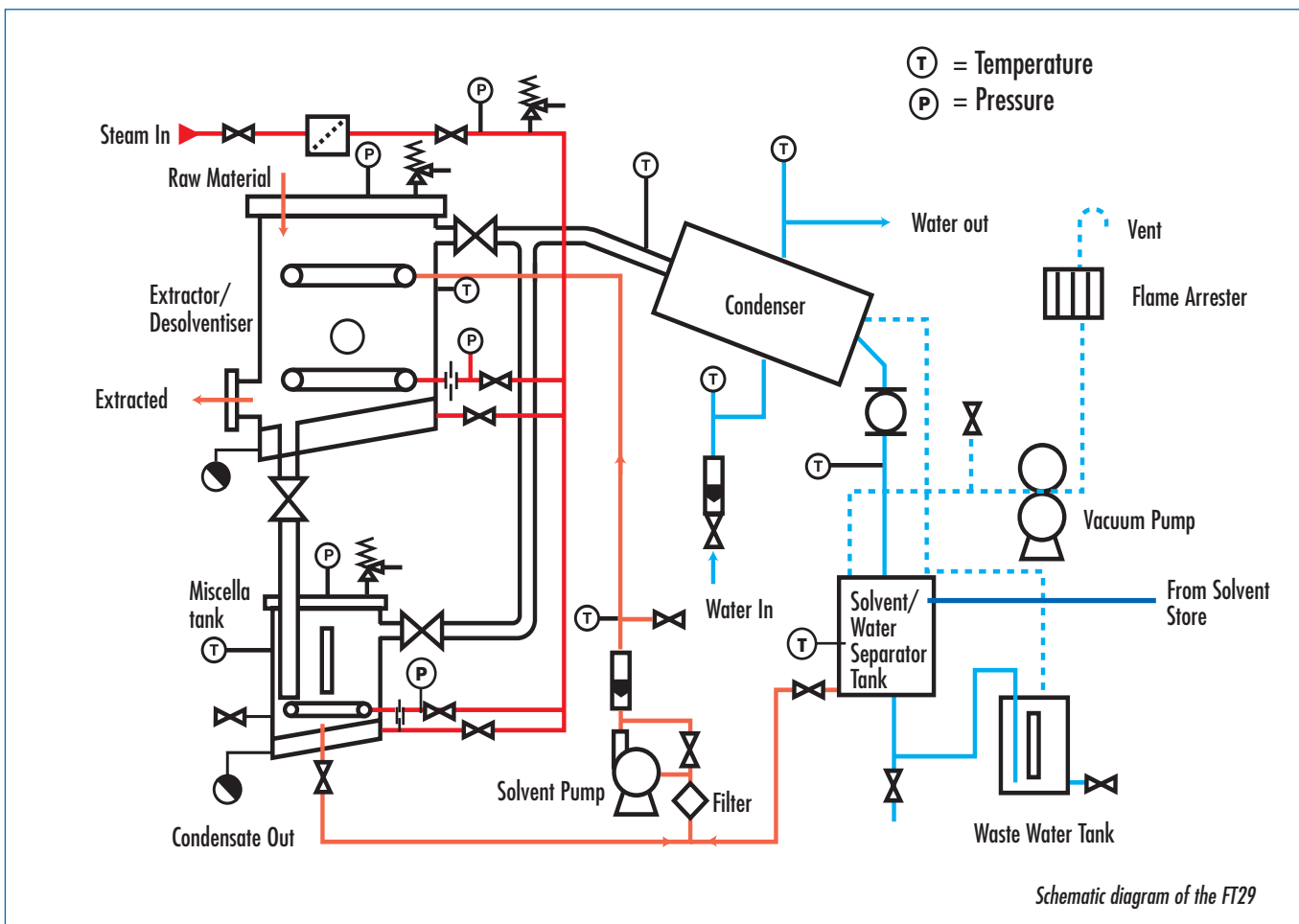

Where electrical equipment must be used, it is specified to the appropriate standards for safety.

The main processing vessels have been designed in accordance with the appropriate code of practice for welded pressure vessels.

Modes of Operation

Extraction by recirculating miscella:

This involves priming the miscella tank with clean solvent then pumping the solvent to the extractor where it percolates through the material bed and drains as miscella back into the tank for recirculation.

Extraction by washing with clean solvent:

As miscella is formed, steam admitted to the miscella tank base causes solvent to evaporate. The vapour is condensed in the solvent condenser and returns to the separator tank from which it is pumped back to the extractor.

Desolventising extracted material:

When the extraction is complete, the static hold-up of solvent remaining in the material must be removed and this is achieved using a combination of direct and indirect steam and vacuum. The solvent vapourises and is condensed along with the condensate. The mixture of solvent and water is separated in the solvent water separator tank. When the extracted material is free of solvent it is discharged through the door at the base of the extractor.

Desolventising miscella:

Miscella is a mixture of the solvent and oil from the extraction material, which accumulates in the miscella tank during the process. The solvent and oil are separated in a similar method as for material desolventising using a combination of direct and indirect steam and vacuum.

A higher level of vacuum is required than for material desolventising in order to produce solvent-free oil.

Within each mode of operation, many operating parameters such as process temperature, solvent temperature, solvent flow rate, direct steam flow rate and system pressure can be adjusted to enable a high degree of experimentation.

Some examples of extractions possible using the FT29

Extraction material	Extract	Solvent
Oilseeds/presscakes	Edible oil	Hexane
Tree bark	Tannin	Water
Solanium (a grass)	Steroid	Dil. sulphuric acid
Pyrethrum flower	Insecticide	Hexane
Tea leaves	Tea	Water
Wheat germ	Oil	Hexane
Rice bran	Oil	Hexane
Poppy stalks	Morphine	Water
Flowers/fruits	Essential oils	Hexane
Liquorice roots	Liquorice juice	Water



Inspecting the interior of the extractor vessel

CAPABILITIES

- Effect of degree of pretreatment of solid material on extraction efficiency
- Effect of solvent type
- Effect of solvent percolation rate
- Effect of process temperature and pressure
- Effect of extraction time and drain time
- Method and degree of solvent recovery

armfield

Develop with us

Armfield R&D products include:

316 Stainless steel ✓

CE certification ✓

Extended warranty as standard ✓



Head Office:

Armfield Limited
Bridge House, West Street,
Ringwood, Hampshire.
BH24 1DY England

Tel: +44 1425 478781
Fax: +44 1425 470916
E-mail: sales@armfield.co.uk

U.S. Office:

Armfield Inc.
9 Trenton - Lakewood Road
Clarksburg NJ 08510
Tel/Fax: (609) 208-2800
E-mail: info@armfieldinc.com

follow us



twitter.com/Armfield_LFT
facebook.com/Armfielduk
linkedin.com/companies/armfield-limited
youtube.com/user/armfieldUK
explorearmfield.wordpress.com



Specifications

Extractor vessel:

Volume: 100 litres
Batch capacity: 25kg based on density of 560kg/m³

Direct steam: 0 - 7kg/hr

Indirect steam: 0 - 3.5 bar

Miscella tank:

Volume: 30 litres

Minimum extract: 2 litres

Direct steam: 0 - 4kg/hr

Indirect steam: 0 - 3.5 bar

Solvent condenser:

Condensing capacity: 2.5kW

Condensing area: 2.5m²

Cooling medium: water

Cooling water flow range: 0 - 22 l/m

Solvent water separator tank:

Volume of separator section: 16 litres

Volume of solvent store: 16 litres

Waste water tank:

Total volume: 15 litres

Vacuum pump:

Type: Double PTFE diaphragm

Drive: Flameproof ac motor

Operating pressure: 100mbar (max)

Solvent pump:

Type: Gear

Drive: Flameproof ac motor

Solvent flow range: 0-18 l/m with bypass flow control

Requirements

Electricity supply: Three phase (see ordering codes)

Water supply: For cooling
25 l/m @ 3 (min)
-5 (max) bar pressure

Steam supply: 20kg/hr @ 5 bar min. pressure

Ordering codes

FT29-C: 415V/3ph/50Hz, (0.6kW)

FT29-D: 208V/3ph/60Hz, (0.6kW)

FT29-E: 380V/3ph/50Hz, (0.6kW)

FT29-F: 220V/3ph/60Hz, (0.6kW)

Shipping specification

Volume: 5.8m³

Gross weight: 880kg

Overall dimensions

Height: 1.75m

Width: 1.90m

Depth: 0.90m

The Armfield range includes HTST/UHT/aseptic systems, carbonator/filler/cappers, spray dryers/chillers, multifunction batch processors, ice cream freezers, margarine crystallisers, extractors, edible oils processors and more. For further information about our products and services, or to book a trial at one of our trials facilities, please contact us.