

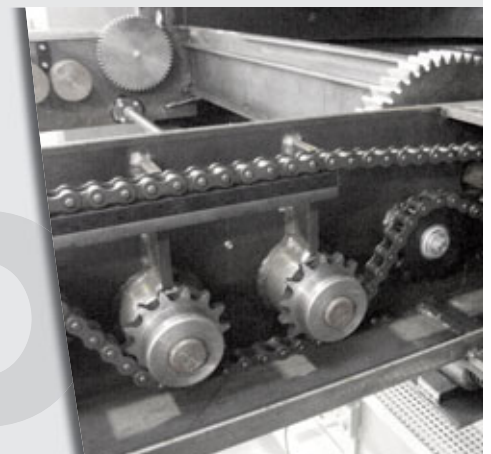

TYPE 360

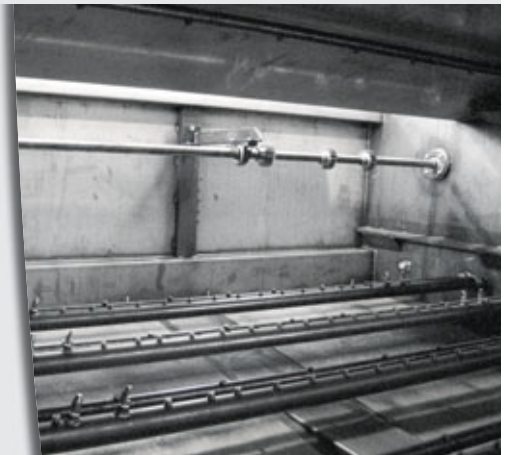

360

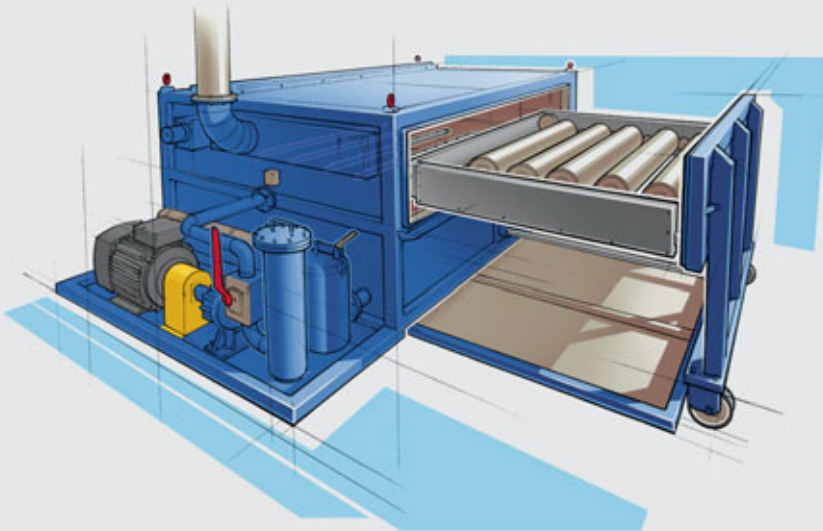

Type 360

Washing machine Typ 360	Size 3	Size 4	Size 5
Number of gravure cylinders	3	4	5
Max. diameter of gravure cylinders	300 mm	300 mm	300 mm
Max. length of gravure cylinders	2000/2500/3000 mm	2000/2500/3000 mm	2000/2500/3000 mm
Capacity of wash pump	80 m³/h, 20 KW	105 m³/h, 28 KW	160 m³/h, 47 KW
Internal exhaust	3000 m³/h, 3,6 KW	4000 m³/h, 3,6 KW	5000 m³/h, 3,6 KW
	Required space mm L x W x D	Dimensions mm L x W x D	Clearance for installation mm L x W x D
Size 3/2000	5500 x 6500 x 3500	3900 x 3080 x 2000	4200 x 3200 x 2300
Size 3/2500	6000 x 6500 x 3500	4400 x 3080 x 2000	4700 x 3200 x 2300
Size 3/3000	6500 x 6500 x 3500	4900 x 3080 x 2000	5200 x 3200 x 2300
Size 4/2000	5500 x 7400 x 3500	3900 x 3520 x 2000	4200 x 3650 x 2300
Size 4/2500	6000 x 7400 x 3500	4400 x 3520 x 2000	4700 x 3650 x 2300
Size 4/3000	6500 x 7400 x 3500	4900 x 3520 x 2000	5200 x 3650 x 2300
Size 5/2000	5500 x 8300 x 3500	3900 x 3960 x 2000	4200 x 4100 x 2300
Size 5/2500	6000 x 8300 x 3500	4400 x 3960 x 2000	4700 x 4100 x 2300
Size 5/3000	6500 x 8300 x 3500	4900 x 3960 x 2000	5200 x 4100 x 2300

Type 360

- Machine to be loaded from the front with closed wash cabin and separate, machine-integrated wash solvent reservoir.
- Pneumatically driven machine infeed, machine door is designed as machine front; operation of washing machine only possible if door is shut.
- Machine infeed with powered rollers for the accommodation of the gravure cylinders. Adjustable rollers are powered by external ex-gear motor.
- Stainless steel catch basins under machine infeed; prevents contamination of floor; moves synchronously to slide-in.
- Individually designed wash and re-rinse spray system
- Powerful wash pump / ex-motor power unit
- Removable filter elements for the protection of spray system, pumps and piping.
- Fill-level control for the integrated

wash solvent reservoir (operation level, max. level)

- Internal exhaust system with powerful ventilator and pneumatically controlled air-intake and air-admixture chokes
- Automatic wash program (PLC), includes washing – drip off – re-rinse – internal exhaust. Individual program steps can be adjusted.

Equipment

- Self-cleaning device
- Solvent cooling, alternatively with thermostatic safety valve, water cooler or recooler
- Workplace vapour extraction
- Measuring and control system of solvent concentration for the connection to a waste-air purification system

Ideal machine design

- Integration into existing rooms and cylinder logistics (see page 7)
- Throughput washing machine with 2 doors (see page 7)
- Itemization 360-W for aqueous alkaline cleaning systems

360