

COMPUTER CONTROLLED HEAT TRANSFER TEACHING EQUIPMENT – HT10XC

NEW ACCESSORY - HT19 FREE & FORCED CONVECTION

The Armfield HT10XC is a service unit, which can be used in conjunction with a range of small scale accessories for a wide range of demonstrations into the modes of heat transfer. The factors that affect heat transfer can be investigated and some of the practical problems associated with the transfer of heat can be clearly demonstrated.

The heat transfer accessories may be individually connected to the HT10XC service unit, which provides the necessary electrical supplies and measurement facilities for investigation and comparison of the different heat transfer characteristics.

KEY FEATURES

- > Small-scale, bench top equipment
- > Common service unit avoids unnecessary cost duplication for control and instrumentation
- > Multiple accessories available covering a wide range of heat transfer investigations
- > Computer control of heaters, water flow, air flow, with safety functions implemented to allow for remote operation
- > Improved accuracy for quantitative results which can be related directly to theory
- > Integral USB interface
- > Full educational software, with data logging, control, graph plotting, and detailed 'Help'

Remote operation capability

A specific feature of the HT10XC is that it incorporates the facilities and safety features to enable the accessories to be remotely controlled from an external computer, if required.

With suitable (user provided) software the equipment can be operated remotely, for instance over an intranet or even over the internet. All the facilities can also be accessed locally using the front panel controls and display.



HT10XC shown with Free and Forced Convection accessory - HT19

ACCESSORIES

The following heat transfer accessories are available for use under manual control:

- HT11: Linear heat conduction
- HT12: Radial heat conduction
- HT13: Laws of radiant heat transfer and radiant heat exchange
- HT14: Combined convection and radiation
- HT15: Extended surface heat transfer
- HT16: Radiation errors in temperature measurement
- HT17: Unsteady state heat transfer
- HT19: Free & forced convection

In addition the following accessories can be used in computer control and remote control applications:

- HT11C: Computer controlled linear heat conduction
(material samples still need changing manually)
- HT12C: Computer controlled radial heat conduction
- HT14C: Computer controlled combined convection and radiation
- HT15: Extended surface heat transfer
- HT16C: Computer controlled radiation errors in temperature measurement
- HT18C: Thermo-electric heat pump

NOTE: The HT13 and the HT17 are not suitable for computer control due to the amount of manual intervention required. The standard HT15 can be used for computer control as no manual intervention is required.

HARDWARE DESCRIPTION

The service unit is housed in a robust steel enclosure and designed for use on a bench or table. It provides control outputs to the accessories, and instrumentation inputs from the accessories.

OUTPUTS:

- > A stabilised, variable low voltage DC supply to the heater of the heat transfer accessory under evaluation
- > Drive to the flow regulation valves used on HT11C and HT12C
- > Drive to the variable speed air blowers used on HT14C and HT16C

INPUTS AND INSTRUMENTATION:

Temperatures: (up to ten off, dependant on accessory being used)

Heater voltage: (All accessories except HT17)

Heater current: (All accessories except HT17)

Heat radiated: (HT13)

Light radiated: (HT13)

Air velocity: (HT14, HT14C, HT16, HT16C, HT19)

Cooling water flowrate: (HT11C, HT12C, HT18C)

In manual mode, the outputs listed above are under control of potentiometers on the front panel of the unit. In remote mode the outputs to the accessories are controlled by the computer.

A 'Watchdog' system is implemented in remote mode to ensure operator and equipment safety in event of a computer or communications failure. In both modes the signals from the accessory can be shown on the front panel displays. Selector switches are used to select the chosen signal onto one of the two displays. These signals are also available on the USB interface for datalogging on the computer (even if the computer is not controlling the equipment).

SOFTWARE

Full educational software is provided with the HT10XC for all the Armfield Heat Transfer Accessories. Separate programs are provided for each accessory, and each program contains a selection of separate exercises that can be performed. The actual details are exercise specific, but typically the following interfaces are available:

- > All the temperatures and other signals such as flow rates, heater voltage and current, etc. are displayed on a diagrammatic representation of the equipment.
- > A software 'button' switches the equipment from 'standby' mode to fully on.
- > The control outputs are operated by using up/down arrows or typing in a value between 0 and 100%. The sensor values can be read directly in engineering units.
- > Data from the sensors is logged into a spreadsheet format, with operator control over the sampling intervals (or 'single-shot').
- > Sophisticated graph plotting facilities are provided, including plotting of both measured and calculated values. Comparisons between data taken on different runs can be displayed. Also the graphs update in real time as the samples are being taken.
- > Student questions and answers, including a layered 'Hint' facility.
- > Processing of measured values to obtain calculated values (this can be linked to the questions and answers to ensure student understanding).
- > The data samples can be saved, or exported in Microsoft Excel format.
- > Data from the sensors can be displayed independently from the data logging. This can be in bar graph format, or a recent history graphical display (useful to check for temperature stability prior to taking a sample).
- > Presentation screens are available, giving an overview of the software, the equipment, the procedure and the associated theory. This is backed up by a detailed 'Help' facility giving in-depth guidance and background information.

SOFTWARE CONTINUED - USER DEFINED SOFTWARE AND/OR REMOTE OPERATION

Included separately on the software CD are the 'drivers' required to enable other software applications to communicate with the HT10XC via the USB system. This enables users to write their own software instead of using the Armfield provided software. This software can be written in many different formats, typically LabVIEW, MatLab, 'C', 'C++', Visual Basic, Delphi, and any other software environment, which allows calls to external drivers can be used.

In this way users can write software to suit their specific requirements, in an environment that they are fully familiar with and which is compatible with their other equipment.

An extension of this methodology enables the equipment to be operated remotely, such as over a Local Area Network (LAN) or even over the internet. The HT10XC is ideal for this remote operation as it has been designed to ensure that the unit shuts down safely in the event of a communications failure. It has also been designed so that once the heat transfer accessory has been installed and configured, all the controls to perform a series of investigations are under software control, and so the student does not need to be present with the equipment.

In a typical installation, the HT10XC would be connected to a local PC via the USB bus. The local PC would be connected to the users' PCs via a Local Area Network. The operator interface software would be run on the remote (users) PC and communicate to the control software on the local PC.

(Note, Armfield do not provide the software to implement this type of system).

For remote use, the appropriate heat transfer accessory would be connected to the service unit and the unit switched on. It remains in 'Standby' mode until appropriate software is run requesting the unit to power up fully. The functions which can be implemented remotely are dependant on the accessory being used. For some accessories the configuration has to be manually implemented locally. E.g. on HT11C the required material sample has to be inserted manually. However, once this has been done, a full set of investigations can be performed for that configuration remotely.

REQUIREMENTS

Single phase electricity supply:

HT10XC-A: 230V, 50Hz, @ 5A

HT10XC-B: 115V, 60 Hz, @ 10A

HT10XC-G: 220V, 60Hz, @ 5A

(current figures are worst case figures, including the supply to appropriate accessory)

OVERALL DIMENSIONS

Height: 0.24m

Width: 0.32m

Depth: 0.39m

SHIPPING SPECIFICATION

Volume: 0.05m³

Gross weight: 15kg

ORDERING SPECIFICATION

HT10XC - COMPUTER CONTROLLED HEAT TRANSFER TEACHING EQUIPMENT

- A bench top service unit designed to interface to a range of heat transfer accessories.
- Provides a variable, stabilised 0-24V DC supply to the heater of the heat transfer accessory, with a current capability of 9A.
- Provides a drive signal for a proportioning solenoid valve used for flow control.
- Provides a control signal to a variable speed blower used for generating airflow.
- Ten temperature inputs and conditioning circuits for K-type thermocouples:
 - > Nine off, 0-133°C, resolution <0.1°C
 - > One off, 0-500°C, resolution <0.15°C
- Instrumentation inputs for heater voltage, heater current, air flow, water flow, radiation and light meter.
- Integral USB interface, and educational software for all accessories.
- Outputs can be controlled manually from the front panel, or controlled by the software from a user supplied PC.
- Easy interfacing to 3rd party software e.g. LabView.
- Watchdog circuit for operator and equipment safety in case of computer or interface failure when being controlled remotely, e.g. over a network or the internet using customer written software.
- A comprehensive instruction manual describing how to carry out the laboratory teaching exercises in non-steady state heat transfer and their analysis as well as assembly, installation and commissioning is included.

FOR FURTHER INFORMATION ON THE ADVANCED FEATURES OF THE SOPHISTICATED ARMFIELD SOFTWARE VISIT:
www.armfield.co.uk/armsoft_datasheet.html

LINEAR HEAT CONDUCTION - HT11 / COMPUTER CONTROLLED LINEAR HEAT CONDUCTION - HT11C



The Armfield Linear Heat Conduction accessories are designed to demonstrate the application of the Fourier Rate equation to simple steady-state conduction in one dimension.

The units can be configured as a simple plane wall of uniform material and constant cross sectional area, or as composite plane walls with different materials or changes in cross sectional area to enable the principles of heat flow by linear conduction to be investigated.

Measurement of the heat flow and temperature gradient enables the thermal conductivity of the material to be calculated. The design allows the conductivity of thin samples of insulating material to be determined.

On the HT11C the heater power and the cooling water flow rate are controlled via the HT10XC, either from the front panel or from the computer software. On the HT11 these are controlled manually.

TECHNICAL DETAILS

The accessory comprises a heating section and cooling section which can be clamped together or clamped with interchangeable intermediate sections between them, as required. The temperature difference created by the application of heat to one end of the resulting wall and cooling at the other end results in the flow of heat linearly through the wall by conduction.

Thermocouples are positioned along both the heated section and cooled sections at uniform intervals of 15mm to measure the temperature gradient along the sections.

A pressure regulator is incorporated to minimise the effect of fluctuations in the supply pressure.

A control valve allows the flow of cooling water to be varied, if required, over the operating range of 0-1.5 litres/min. The cooling water flowrate is measured by a turbine type flow sensor (HT11C only).

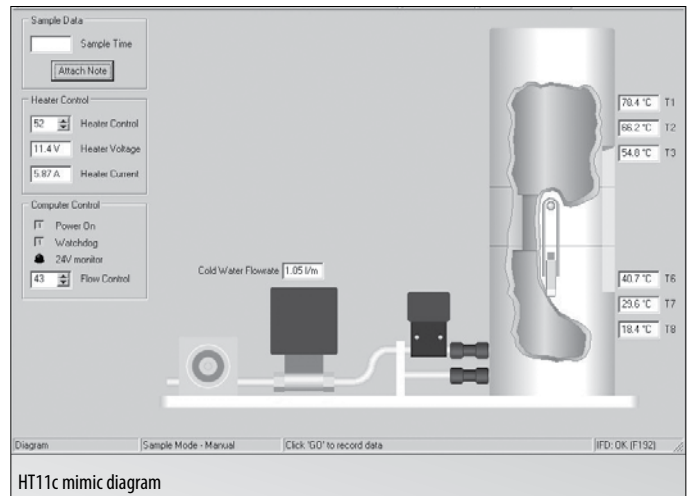

Four intermediate sections are supplied as follows:

- > 30mm long brass section of the same diameter as the heating and cooling sections and fitted with two thermocouples at the same intervals. When this section is clamped between the heating and cooling sections a long plane wall of uniform material and cross section is created with temperatures measured at eight positions.
 - > Stainless steel section of the same dimensions as the brass section to demonstrate the effect of a change in thermal conductivity.
 - > Aluminium section of the same dimensions as the brass section to demonstrate the effect of a change in thermal conductivity.
 - > 30mm long brass section reduced in diameter to 13mm to demonstrate the effect of a change in cross sectional area.
- The heat conducting properties of insulators may be found by simply inserting the paper or cork specimens supplied between the heating and cooling sections.

A tube of thermal paste is provided to demonstrate the difference between good and poor thermal contact between the sections.

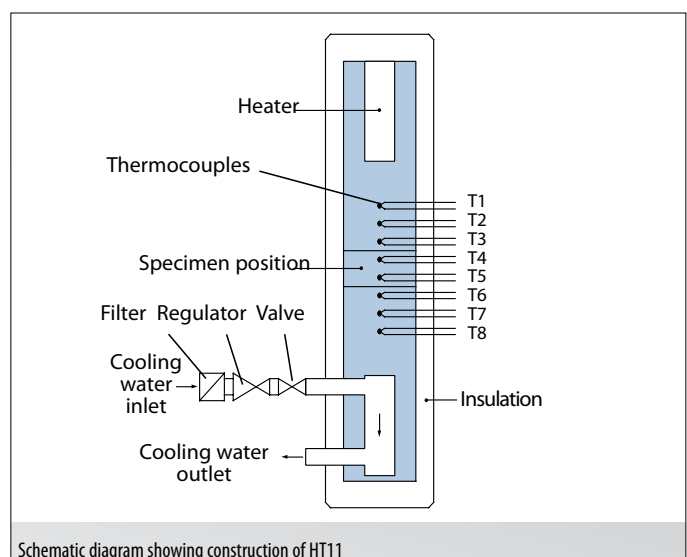

EXPERIMENTAL CAPABILITIES

- > Understanding the use of the Fourier Rate Equation in determining rate of heat flow through solid materials.
- > Measuring the temperature distribution for steady-state conduction of energy through a uniform plane wall and a composite plane wall.
- > Determining the constant of proportionality (thermal conductivity k) of different materials (conductors and insulators).
- > Measuring the temperature drop at the contact face between adjacent layers in a composite plane wall (contact resistance).
- > Measuring the temperature distribution for steady-state conduction of energy through a plane wall of reduced cross-sectional area.
- > Understanding the application of poor conductors (insulators).
- > Observing unsteady-state conduction (qualitative only).

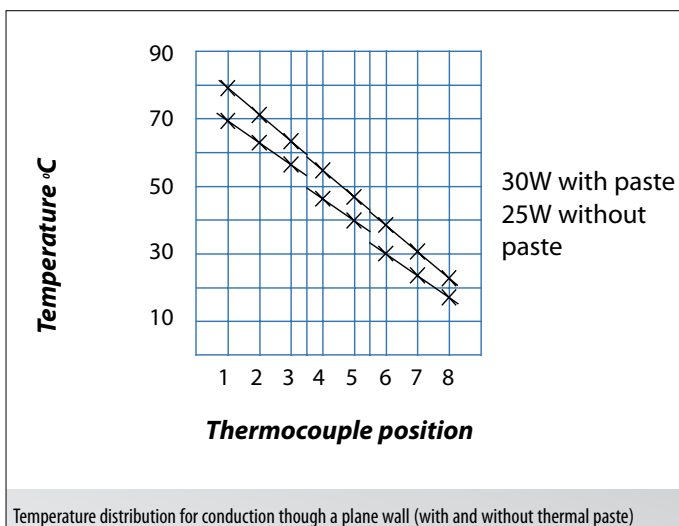
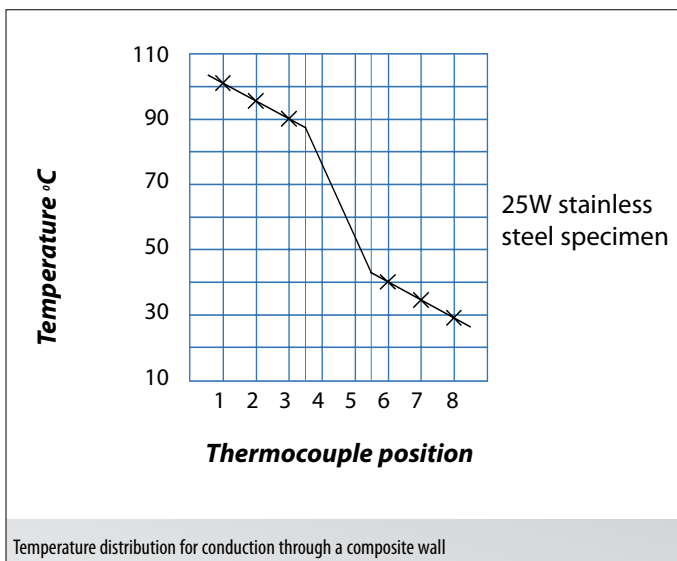

ESSENTIAL ACCESSORIES

HT10XC Computer Controlled Heat Transfer Service Unit.

REQUIREMENTS

Cold water supply: 1.5 litres/min @ 1 Barg

All electrical requirements are obtained from the service unit.

OVERALL DIMENSIONS

HT11:	HT11C:
Height: 0.29m	Height: 0.29m
Width: 0.43m	Width: 0.43m
Depth: 0.21m	Depth: 0.21m

SHIPPING SPECIFICATION

HT11:	HT11C:
Volume: 0.04m ³	Volume: 0.4m ³
Gross weight: 5kg	Gross Weight: 6kg

ORDERING SPECIFICATION

HT11 - LINEAR HEAT CONDUCTION / HT11C - COMPUTER CONTROLLED LINEAR HEAT CONDUCTION

- A small scale accessory to introduce students to the principles of linear heat conduction, and to enable the conductivity of various solid conductors and insulators to be measured.
- Comprises a heating section, a cooling section, plus four intermediate section conductor samples and two insulator samples.
- The heating section, cooling section and one of the intermediate sections are fitted with thermocouples (eight in total) evenly spread along the length of the assembled conduction path.
- All sections are thermally insulated to minimise errors due to heat loss.
- HT11 includes a water pressure regulator and a manual flow control valve.
- HT11C includes a water pressure regulator, an electronic proportioning solenoid valve to control the cooling water flow rate and a water flowmeter.
- Heater power variable up to 60 Watts.
- Water flow rate variable up to 1.5 litres/minute.
- Heating and cooling sections, 25mm diameter.
- A comprehensive instruction manual is included.

RADIAL HEAT CONDUCTION - HT12 / COMPUTER CONTROLLED RADIAL HEAT CONDUCTION - HT12C



Computer Controlled Radial Heat Conduction - HT12C

The Armfield Radial Heat Conduction accessories have been designed to demonstrate the application of the Fourier Rate equation to simple steady-state conduction radially through the wall of a tube. The arrangement, using a solid metal disk with temperature measurements at different radii and heat flow radially outwards from the centre to the periphery, enables the temperature distribution and flow of heat by radial conduction to be investigated.

On the HT12C the heater power and the cooling water flow rate are controlled via the HT10XC, either from the front panel or from the computer software. On the HT12 these are controlled manually.

TECHNICAL DETAILS

The accessory comprises a solid disk of material which is heated at the centre and cooled at the periphery to create a radial temperature difference with corresponding radial flow of heat by conduction.

Six K-type thermocouples are positioned at different radii in the heated disk to indicate the temperature gradient from the central heated core to the periphery of the disk. The radial distance between each thermocouple in the disk is 10mm. Quick-release connections facilitate rapid connection of the cooling tube to a cold water supply. A pressure regulator is incorporated to minimise the effect of fluctuations in the supply pressure. A control valve permits the flow of cooling water to be varied, if required, over the operating range of 0 -1.5 litres/min. The cooling water flowrate is measured by a turbine type flow sensor (HT12C only).

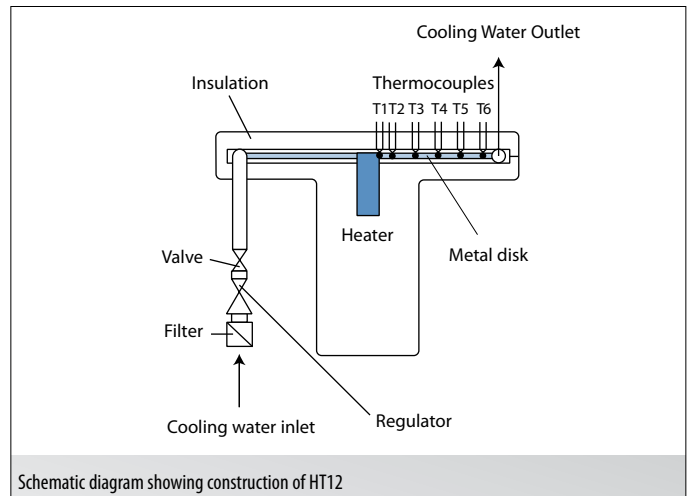

Schematic diagram showing construction of HT12

EXPERIMENTAL CAPABILITIES

- > Understanding the use of the Fourier Rate Equation in determining rate of heat flow through solid materials.
- > Measuring the temperature distribution for steady-state conduction of energy through the wall of a cylinder (radial energy flow).
- > Determining the constant of proportionality (thermal conductivity k) of the disk material.

ESSENTIAL ACCESSORIES

HT10XC Computer Controlled Heat Transfer Service Unit.

REQUIREMENTS

Cold water supply: 1.5 litres/min @ 1 Barg

All electrical requirements are obtained from the service unit.

OVERALL DIMENSIONS

HT12:		HT12C:	
Height:	0.19m	Height:	0.19m
Width:	0.35m	Width:	0.43m
Depth:	0.18m	Depth:	0.18m

SHIPPING SPECIFICATION

HT12:		HT12C:	
Volume:	0.03m ³	Volume:	0.4m ³
Gross weight:	5kg	Gross Weight:	6kg

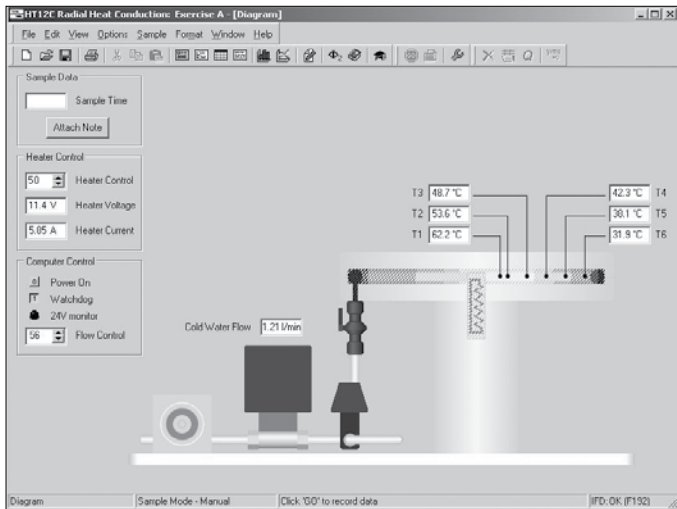

Educational software displaying Mimic diagram of HT12

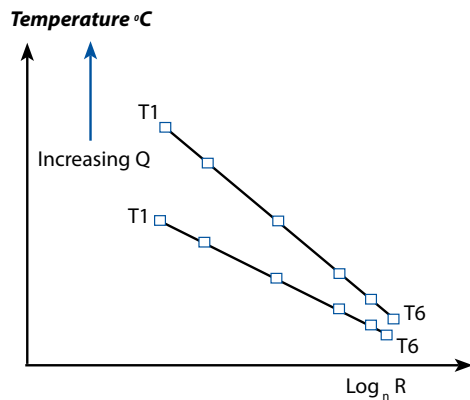

Temperature distribution for radial conduction through the wall of a cylinder

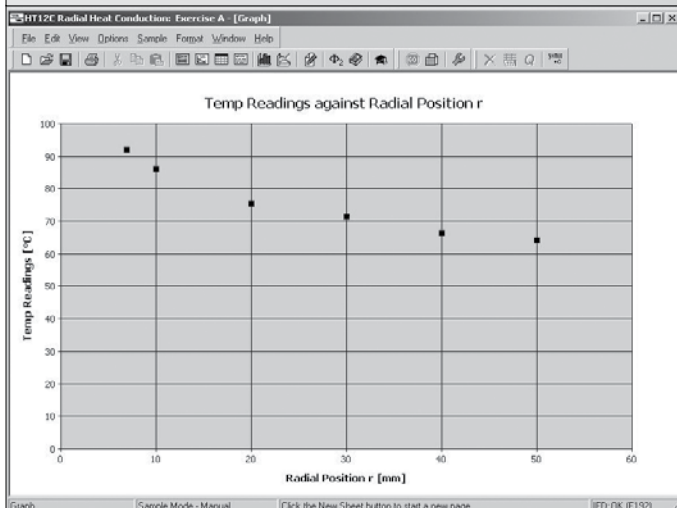

HT12 graphical analysis

ORDERING SPECIFICATION

HT12 - RADIAL HEAT CONDUCTION / HT12C - COMPUTER CONTROLLED RADIAL HEAT CONDUCTION

- A small scale accessory to introduce students to the principles of radial heat conduction, and to enable the conductivity of a solid brass disk to be measured
- Comprises a brass disk with a heater at the centre and a cooling water tube attached to the periphery
- Six thermocouples measure the temperature gradient between the heated centre and the cooled periphery of the disk
- Thermally insulated to minimise errors due to heat loss
- HT12 includes a water pressure regulator and a manually operated valve to control the flow rate
- HT12C includes an electronic proportioning solenoid valve to control the cooling water flow rate, a pressure regulator and a water flowmeter
- Heater power variable up to 100 Watts
- Water flow rate variable up to 1.5 litres/ minute
- Conduction disk is 110mm diameter and 3.2mm thick
- A comprehensive instruction manual is included

LAWS OF RADIANT HEAT TRANSFER AND RADIANT HEAT EXCHANGE - HT13



Radiant heat transfer - HT13

This Armfield accessory has been designed to demonstrate the laws of radiant heat transfer and radiant heat exchange using light radiation to complement the heat demonstrations where the use of thermal radiation would be impractical.

The equipment supplied comprises an arrangement of energy sources, measuring instruments, aperture plates, filter plates and target plates which are mounted on a linear track, in different combinations, to suit the particular laboratory teaching exercise chosen.

TECHNICAL DETAILS

The track consists of a rigid aluminium frame with twin horizontal rails which incorporates sliding carriages to enable the positions of the instrumentation, filters and plates to be varied. The position of the carriages relative to the energy source can be measured using a graduated scale attached to the side of the track. The track is designed to stand on the bench top alongside the HT10XC Heat Transfer Service Unit. The heat source consists of a flat copper plate which is heated from the rear by an insulated electric heating element, which operates at low voltage for increased operator safety. The front of the plate is coated with a heat resistant matt black paint, which provides a consistent emissivity close to unity. The surface temperature of the plate is measured by a thermocouple, which is attached to the front of the plate.

Radiation from the heated plate is measured using a heat radiation detector (radiometer) which can be positioned along the graduated track on a carriage. Metal plates with different surface finishes are supplied to demonstrate the effect of emissivity on radiation emitted and received. Two black plates, one grey plate and one polished plate are supplied together with a track mounted carrier which positions the plates in front of the heat source. Each plate incorporates a thermocouple to indicate the surface temperature of the plate.

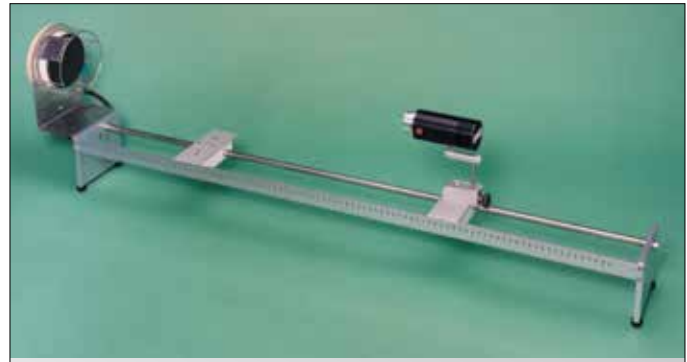

Radiant heat exchange - HT13

Two cork-coated metal plates are supplied that enable a vertical slot aperture of adjustable width to be created between the source and detector to demonstrate area factors. The light source consists of a lamp in a housing with a glass diffuser and operates at low voltage for increased operator safety. The source may be rotated through 180° and the angle measured using an integral scale. The power supplied to the lamp can be varied and measured on the HT10XC.

The Radiation from the light source is measured using a light meter which can be positioned along the graduated track on a carriage. Filter plates of varying opacity and thickness are supplied to demonstrate the laws of absorption.

EXPERIMENTAL CAPABILITIES

- > Inverse Square Law using the heat source and radiometer or light source and light meter
- > Stefan Boltzmann Law using the heat source and radiometer.
- > Emissivity using the heat source, metal plates and radiometer.
- > Kirchoff Law using the heat source, metal plates and radiometer.
- > Area factors using the heat source, aperture and radiometer.
- > Lamberts Cosine Law using the light source (rotated) and light meter.
- > Lamberts Law of Absorption using the light source, filter plates and light meter.

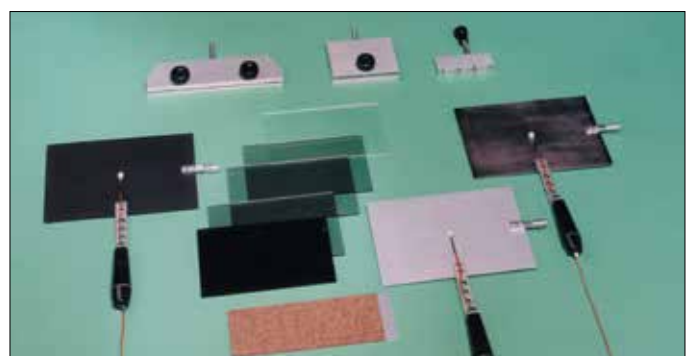

HT13 accessories

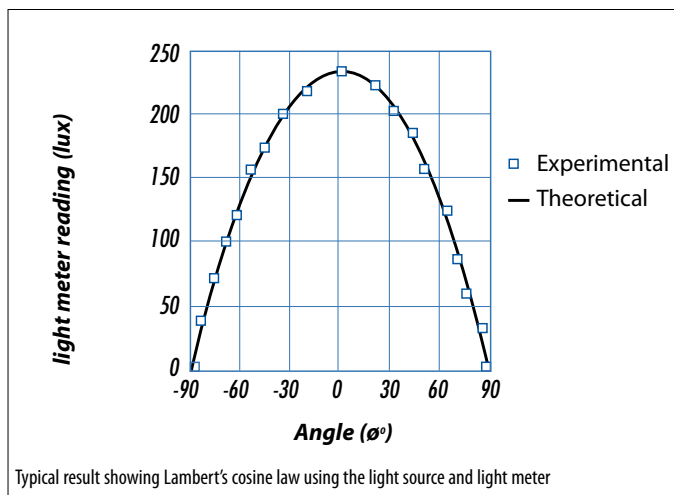
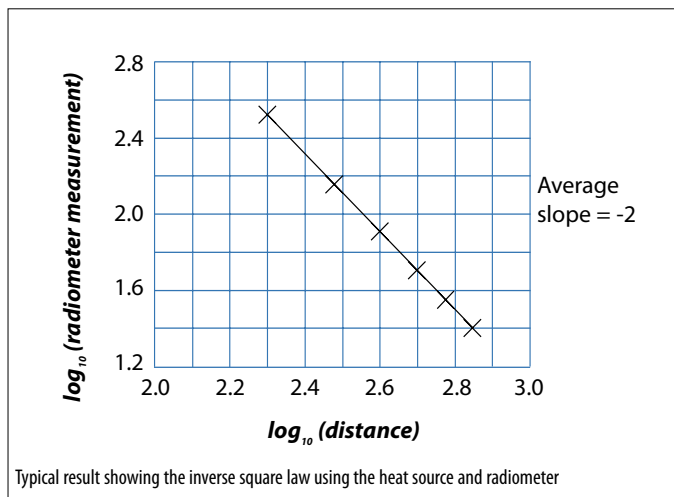
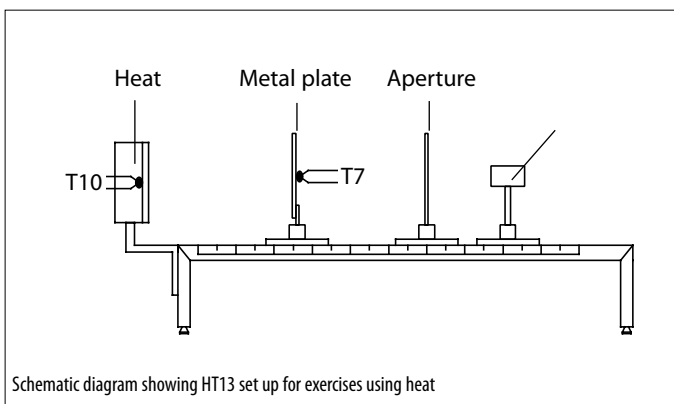
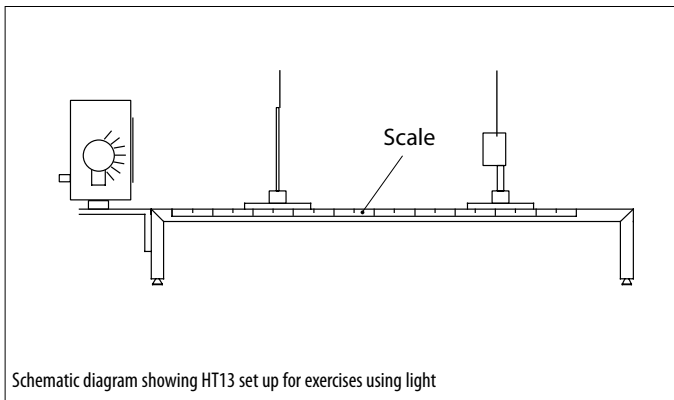

ESSENTIAL ACCESSORIES

HT10XC Computer Controlled Heat Transfer Service Unit.

OVERALL DIMENSIONS

Height: 0.44m
 Width: 1.23m
 Depth: 0.30m

SHIPPING SPECIFICATION

Volume: 0.3m³
 Gross Weight: 12kg

ORDERING SPECIFICATION

HT13 - LAWS OF RADIANT HEAT TRANSFER AND RADIANT HEAT EXCHANGE

- A small scale accessory designed to introduce students to the basic laws of radiant heat transfer and radiant heat exchange.
- A heat source with radiometer and a light source with light meter are used where appropriate to demonstrate the principles.
- The heat source consists of a flat circular plate 100mm in diameter which incorporates a 216 Watt electric heating element (operating at 24V DC maximum).
- The light source consists of a 60 Watt light bulb (operating at 24V DC maximum) mounted inside a housing with a glass diffuser.
- The heat and light sources, instruments, filters and plates are mounted on an aluminium track with graduated scale which is designed to stand on the bench top and connect to the Heat Transfer Service Unit without the need for tools.
- A comprehensive instruction manual describing how to carry out the laboratory teaching exercises in radiant heat transfer/exchange and their analysis as well as assembly, installation and commissioning is included.

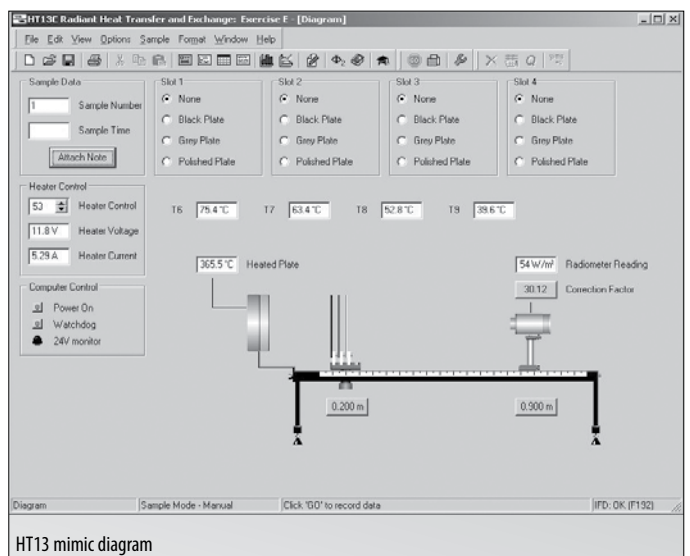

COMBINED CONVECTION AND RADIATION - HT14

COMPUTER CONTROLLED COMBINED CONVECTION AND RADIATION - HT14C



Computer Controlled Combined Convection and Radiation - HT14C

A hot surface loses heat (heat is transferred) to its surroundings by the combined modes of convection and radiation. In practice these modes are difficult to isolate and therefore an analysis of the combined effects at varying surface temperature and air velocity over the surface provides a meaningful teaching exercise.

The heated surface studied is a horizontal cylinder, which can be operated in free convection or forced convection when located in the stream of moving air. Measurement of the surface temperature of the uniformly heated cylinder and the electrical power supplied to it enables the combined effects of radiation and convection to be compared with theoretical values. The dominance of convection at lower surface temperatures and the dominance of radiation at higher surface temperatures can be demonstrated as can the increase in heat transfer due to forced convection.

On the HT14C, the heater power and the air flow are controlled via the HT10XC, either from the front panel, or from the computer software. On HT14 these are controlled manually.

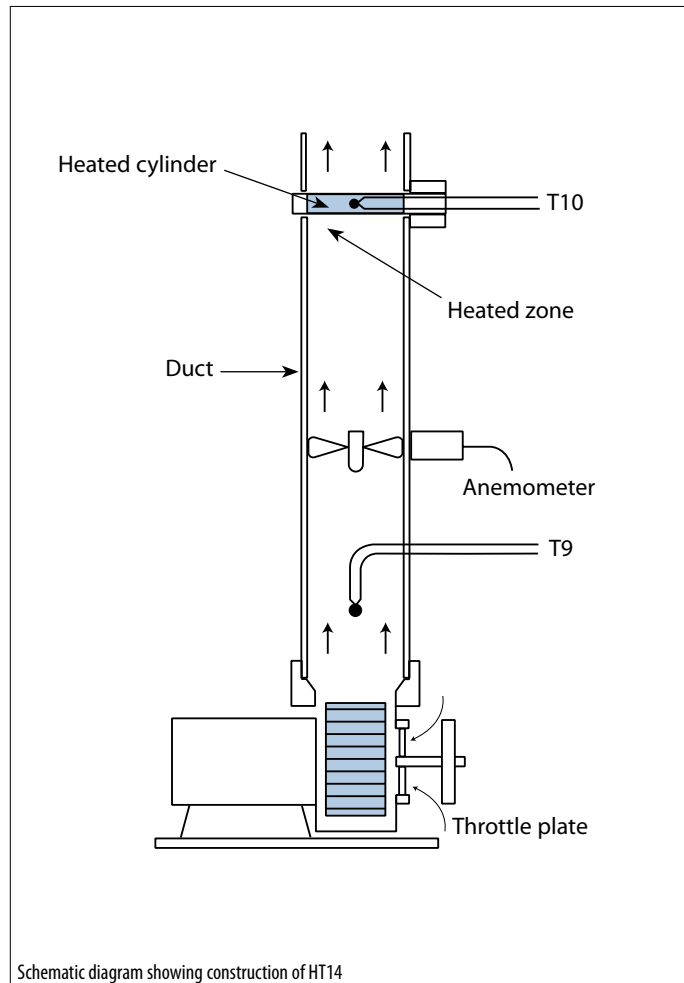

Schematic diagram showing construction of HT14

TECHNICAL DETAILS

The equipment consists of a centrifugal fan with a vertical outlet duct. At the top of the duct there is a heated cylinder. The mounting arrangement for the cylinder in the duct is designed to minimise loss of heat by conduction to the wall of the duct.

The surface of the cylinder is coated with heat resistant paint which provides a consistent emissivity close to unity. A K-type thermocouple (T10) attached to the wall of the cylinder, at mid position, enables the surface temperature to be measured under the varying operating conditions.

A variable fan blows air through the outlet duct and a vane type anemometer within the fan outlet duct enables the air velocity in the duct to be measured. On the HT14C the fan is a variable speed fan with electronic control.

On HT14 a manually adjustable throttle plate permits the air velocity to be varied. A K-type thermocouple (T9) located in the outlet duct allows the ambient air temperature to be measured upstream of the heated cylinder.

EXPERIMENTAL CAPABILITIES

- > Determining the combined heat transfer ($Q_{\text{radiation}} + Q_{\text{convection}}$) from a horizontal cylinder in natural convection over a wide range of power inputs and corresponding surface temperatures.
- > Measuring the domination of the convective heat transfer coefficient H_c at low surface temperatures and the domination of the radiation heat transfer coefficient H_r at high surface temperatures.
- > Determining the effect of forced convection on the heat transfer from the cylinder at varying air velocities.

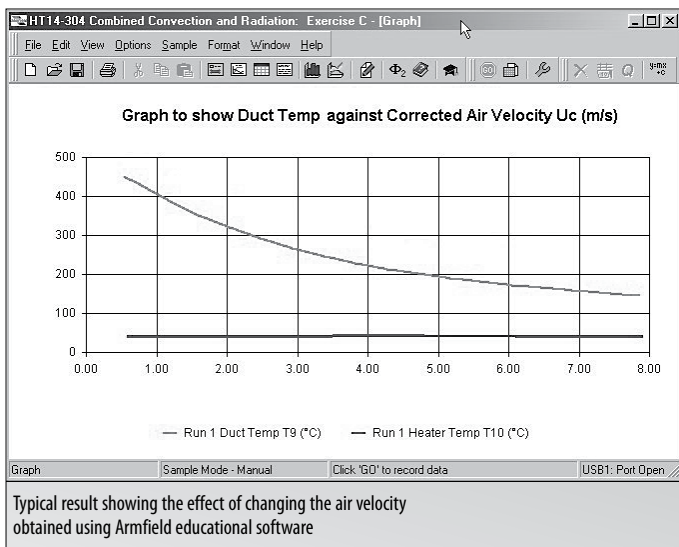
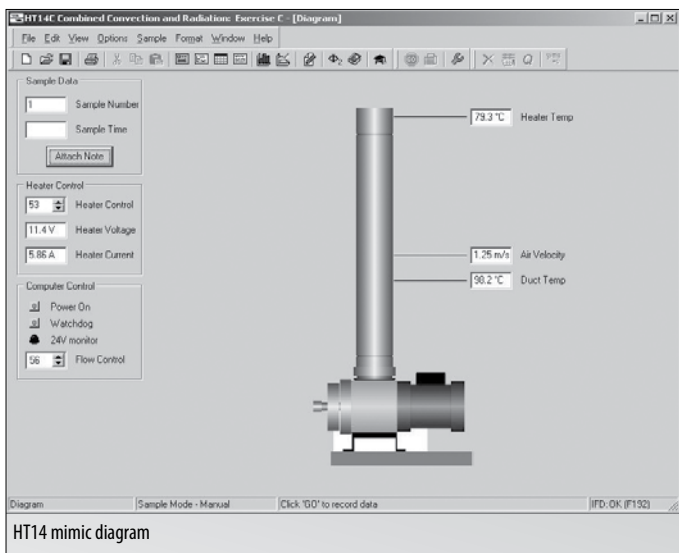

ESSENTIAL ACCESSORIES

HT10XC Computer Controlled Heat Transfer Service Unit.

REQUIREMENTS

All electrical requirements are obtained from the service unit.

NOTE: the supply rating of the HT14/HT14C must be the same as that of the HT10XC that it is used with, i.e.

HT14-A, HT14C-A: 230V/1ph/50Hz

HT14-B, HT14C-B: 115V/1ph/60Hz

HT14-G, HT14C-G: 230V/1ph/60Hz

OVERALL DIMENSIONS

HT14:	HT14C:
Height: 1.20m	Height: 1.20m
Width: 0.35m	Width: 0.49m
Depth: 0.30m	Depth: 0.44m

SHIPPING SPECIFICATION

HT14:	HT14C:
Volume: 0.1m ³	Volume: 0.2m ³
Gross weight: 9kg	Gross Weight: 13kg

ORDERING SPECIFICATION

HT14 - COMBINED CONVECTION AND RADIATION
HT14C - COMPUTER CONTROLLED COMBINED CONVECTION AND RADIATION

- A small scale accessory to introduce students to the principles of combined convection (free and forced) with radiation from a horizontal heated cylinder.
- Comprises a heated cylinder mounted in a vertical air duct, with a fan at the base of the duct, which can be used to provide a variable air flow over the cylinder.
- Heater rating 100 Watt at 24V DC.
- K-type thermocouples measure the air temperature upstream and the surface temperature of the cylinder.
- On HT14C the air flow is electronically adjustable over the range 0 - 7 m/s by an variable speed fan.
- On HT14 the air flow is manually adjustable
- The air flow rate is measured by a vane type anemometer in the outlet duct.
- The accessory is mounted on a PVC baseplate, which is designed to stand on the bench top and connect to the Heat Transfer Service Unit without the need for tools.
- A comprehensive instruction manual is included.

EXTENDED SURFACE HEAT TRANSFER - HT15

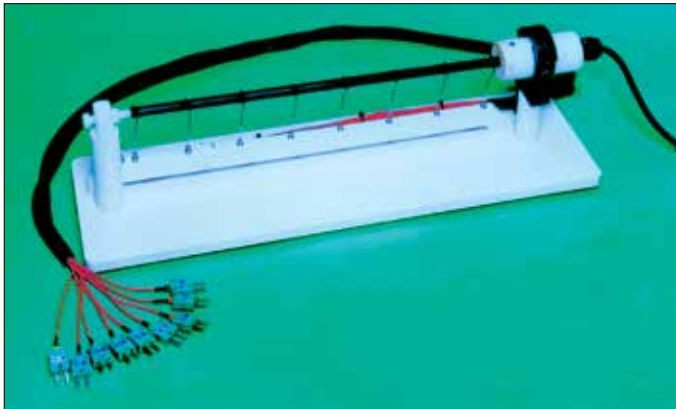

Extended Surface Heat Transfer - HT15

A long horizontal rod, which is heated at one end, provides an extended surface (pin) for heat transfer measurements. Thermocouples at regular intervals along the rod allow the surface temperature profile to be measured. By making the diameter of the rod small in relation to its length, thermal conduction along the rod can be assumed to be one-dimensional and heat loss from the tip can be ignored. The measurements obtained can be compared with a theoretical analysis of thermal conduction along the bar combined with heat loss (heat transferred) to the surroundings by the modes of free convection and radiation simultaneously.

TECHNICAL DETAILS

The rod is manufactured from brass and mounted horizontally with support at both ends positioned to avoid the influence of adjacent surfaces. The rod is coated with a heat resistant matt black paint which provides a consistent emissivity close to unity.

It is heated by an electric heating element which operates at low voltage for increased operator safety and is protected by a thermostat to prevent damage from overheating.

Eight thermocouples are attached to the surface of the rod at equal intervals of 50mm giving an overall instrumented length of 350mm. Another thermocouple is mounted adjacent to the heated rod to measure the ambient air temperature. The heated end of the rod is mounted co-axially inside a plastic housing which provides an air gap and insulates the area occupied by the heater to minimise heat loss and prevent burns to the operator.

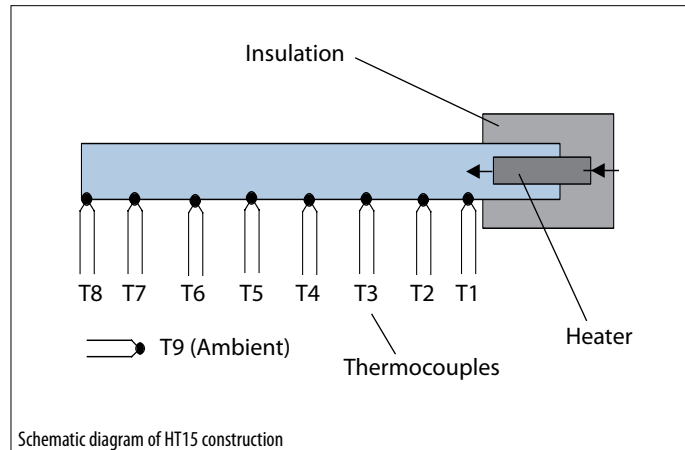

EXPERIMENTAL CAPABILITIES

- > Measuring the temperature distribution along an extended surface (pin) and comparing the result with a theoretical analysis.
- > Calculating the heat transfer from an extended surface resulting from the combined modes of free convection and radiation heat transfer and comparing the result with a theoretical analysis.

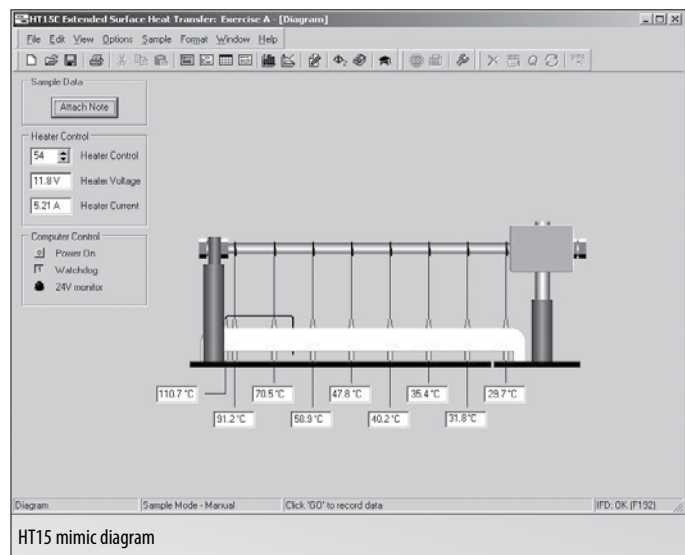

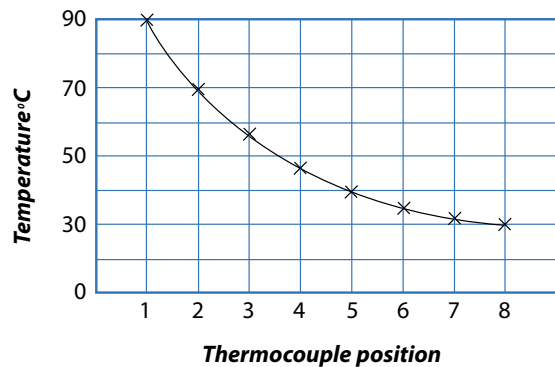

Typical result showing temperature profile along the extended surface

ESSENTIAL ACCESSORIES

HT10XC Computer Controlled Heat Transfer Service Unit.

OVERALL DIMENSIONS

Height: 0.15m
 Width: 0.50m
 Depth: 0.15m

SHIPPING SPECIFICATION

Volume: 0.01m³
 Gross Weight: 5kg

ORDERING SPECIFICATION

HT15 - EXTENDED SURFACE HEAT TRANSFER

- A small scale accessory designed to demonstrate the temperature profiles and heat transfer characteristics for an extended surface when heat flows along the rod by conduction and heat is lost along the rod by combined convection and radiation to the surroundings.
- The extended surface comprises a 10mm diameter long solid brass rod mounted horizontally and heated at one end with a 20 Watt, 24V DC heater.
- Eight thermocouples mounted at 50mm intervals along the rod provide the temperature distribution.
- The temperature of the ambient air is measured by an independent thermocouple.
- The accessory is mounted on a PVC baseplate which is designed to stand on the bench top and connect to the Heat Transfer Service Unit without the need for tools
- A comprehensive instruction manual is included.

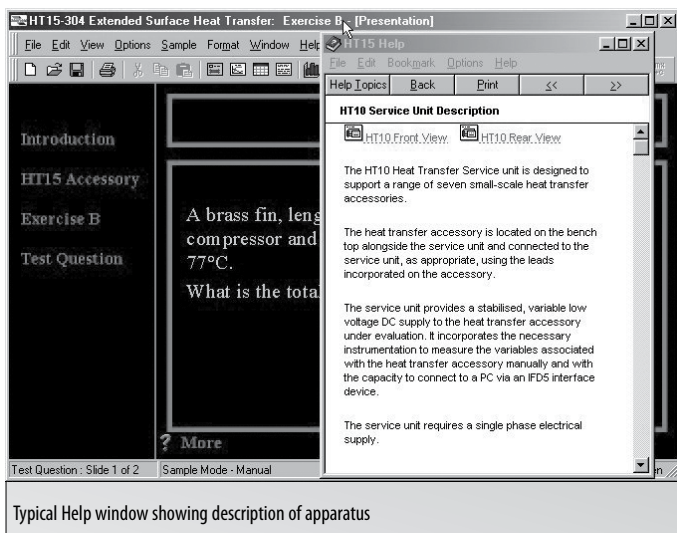

Typical Help window showing description of apparatus

RADIATION ERRORS IN TEMPERATURE MEASUREMENT - HT16

COMPUTER CONTROLLED RADIATION ERRORS IN TEMPERATURE MEASUREMENT - HT16C



Computer Controlled Radiation Errors in Temperature Measurement - HT16C

Radiative heat transfer between a thermometer and its surroundings may significantly affect the temperature reading obtained from the thermometer, especially when the temperature of a gas is to be measured while the thermometer 'sees' surrounding surfaces at a higher or lower temperature than the gas. The error in the reading from the thermometer is also affected by other factors such as the gas velocity over the thermometer, the physical size of the thermometer and the emissivity of the thermometer body. In this equipment a group of thermocouples are used to measure the temperature of a stream of air, at ambient temperature, passing through the centre of a duct while the wall of the duct is elevated in temperature to subject the thermocouples to a source of thermal radiation.

Each thermocouple gains heat by radiation from the heated wall and loses heat by convection to the air stream and conduction along the wire. The net result is an increase in the temperature of the thermocouple above the temperature of the air stream which it is supposed to measure. The result is an error in the reading from the thermocouple. A radiation shield can be positioned in the duct to show the effect of screening the thermocouples from thermal radiation from the duct wall.

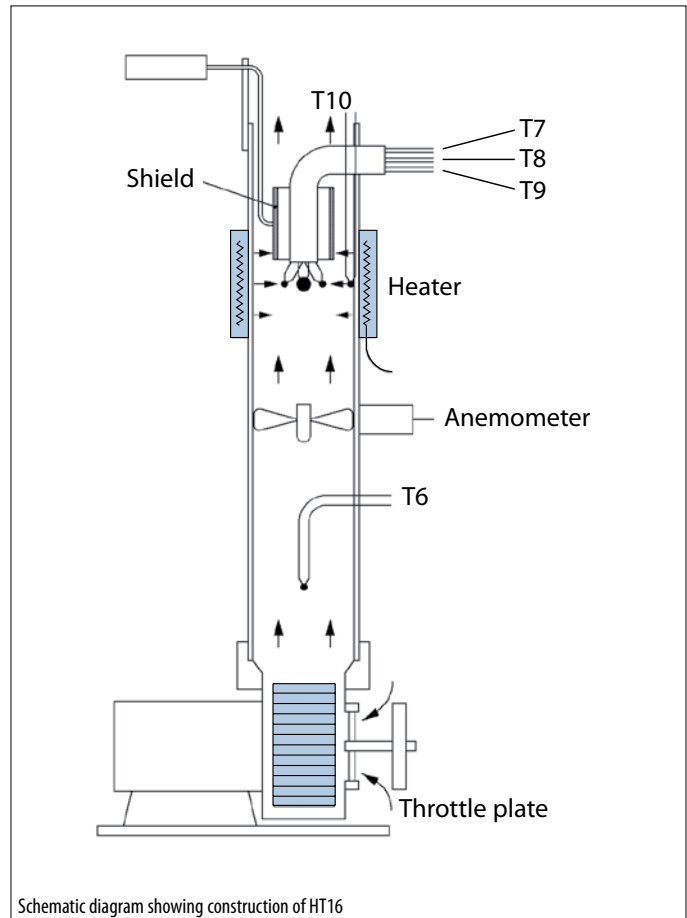

On the HT16C the heater power, the air flow rate and the position of the radiation shield can all be controlled via the HT10XC, either from the front panel controls or from the software. On HT16, these parameters are adjusted manually.

TECHNICAL DETAILS

The equipment comprises a tubular metal duct through which air, at ambient temperature, is blown vertically upwards by an electric fan.

A section of the duct wall is heated from the outside by an electric band heater and provides the source of radiation to the test thermocouples. Three thermocouples with different styles or sizes of bead are installed in the duct to demonstrate the differences in readings obtained.

The temperature of the heated wall can be changed by varying the power supplied to the heater. The actual temperature of the heated surface is measured using another thermocouple which is attached to it. The effect of the duct wall temperature on the measurement thermocouples can be demonstrated. A further thermocouple is installed upstream of the heated section to measure the temperature of the ambient air passing over the thermocouples at the core of the duct.

EXPERIMENTAL CAPABILITIES

The effect of air velocity past the test thermocouples can be demonstrated by adjusting the air flow. On the HT16C this is achieved by a variable speed fan with electronic control. On HT16 the fan is fixed speed with a manually adjustable throttle plate.

A vane type anemometer within the fan outlet duct enables the air velocity through the heated section to be measured.

A radiation shield, which remains close to the air temperature, can be raised or lowered over the thermocouples to demonstrate the change in readings when a radiation shield is used.

On HT16C this radiation shield is controlled by an electro-mechanical servo actuator under software control.

On HT16 the radiation shield is positioned manually.

EXPERIMENTAL CAPABILITIES

- > Errors associated with radiative heat transfer:
 - o Effect of wall temperature on measurement error
 - o Effect of air velocity on measurement error
 - o Effect of thermocouple style on measurement error
- > Methods for reducing errors due to radiation:
 - o Design of a radiation resistant thermometer
 - o Use of a radiation shield to surround the thermometer

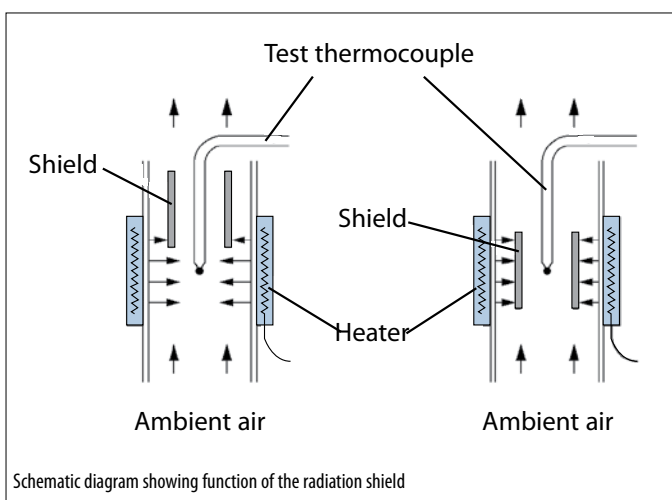

ESSENTIAL ACCESSORIES

HT10XC Computer Controlled Heat Transfer Service Unit.

REQUIREMENTS

All electrical requirements are obtained from the service unit.

NOTE: the supply rating of the HT16/HT16C must be the same as that of the HT10XC that it is used with, i.e.

HT16-A, HT16C-A: 230V/1ph/50Hz

HT16-B, HT16C-B: 115V/1ph/60Hz

HT16-G, HT16C-G: 230V/1ph/60Hz

OVERALL DIMENSIONS

HT16:	HT16C:
Height: 1.22m	Height: 1.19m
Width: 0.30m	Width: 0.49m
Depth: 0.35m	Depth: 0.44m

SHIPPING SPECIFICATION

HT16:	HT16C:
Volume: 0.1m ³	Volume: 0.2m ³
Gross weight: 9kg	Gross Weight: 15kg

ORDERING SPECIFICATION

HT16 - RADIATION ERRORS IN TEMPERATURE MEASUREMENT
HT16C - COMPUTER CONTROLLED RADIATION ERRORS IN TEMPERATURE MEASUREMENT

- A small scale accessory to demonstrate how temperature measurements can be influenced by sources of thermal radiation
- Comprises three K-type thermocouples with different styles of bead mounted in a vertical air duct. A fan at the base of the duct provides a variable air flow over the cylinder. A band heater heats the duct wall adjacent to the thermocouple beads
- Heater rating 216 Watt at 24V DC
- K-type thermocouples measure the air temperature upstream and the surface temperature of the heated duct section
- On HT16C the air flow is electronically adjustable over the range 0 - 9m/s by a variable speed fan
- On HT16 the air flow is manually adjustable
- The air flow rate is measured by a vane type anemometer in the outlet duct
- A radiation shield can be lowered over the thermocouples to demonstrate the improvement in reading accuracy when the thermocouples are shielded from the source of radiation (On HT16C this is electronically activated, on HT16 it is manually positioned.)
- The accessory is mounted on a PVC baseplate, which is designed to stand on the bench top and connect to the Heat Transfer Service Unit without the need for tools
- A comprehensive instruction manual is included



Analytical solutions are available for temperature distribution and heat flow as a function of time and position for simple solid shapes, which are suddenly subjected to convection with a fluid at a constant temperature. Simple shapes are provided together with appropriate classical transient-temperature/heat flow charts, which enable a fast analysis of the response from actual transient measurements. Each shape is allowed to stabilise at room temperature then suddenly immersed in a bath of hot water at a steady temperature. Monitoring of the temperature at the centre of the shape allows analysis of heat flow using the appropriate transient-temperature/heat flow charts provided.

An independent thermocouple mounted alongside the shape indicates the temperature of the water adjacent to the shape and provides an accurate datum for measurement of the time since immersion in the hot water.

TECHNICAL DETAILS

The equipment consists of a heated water bath together with set of instrumented shaped test pieces. Each of the shapes incorporates a thermocouple to measure the temperature at the centre of the shape.

A total of six shaped test pieces are provided, i.e. three simple shapes (a rectangular slab, a long solid cylinder and a solid sphere) each manufactured in two different materials (brass and stainless steel). Measurements taken on a shape in one material can be used to confirm the conductivity of a similar shape constructed from a different material. Transient-temperature/heat flow charts are supplied for each of the shapes.

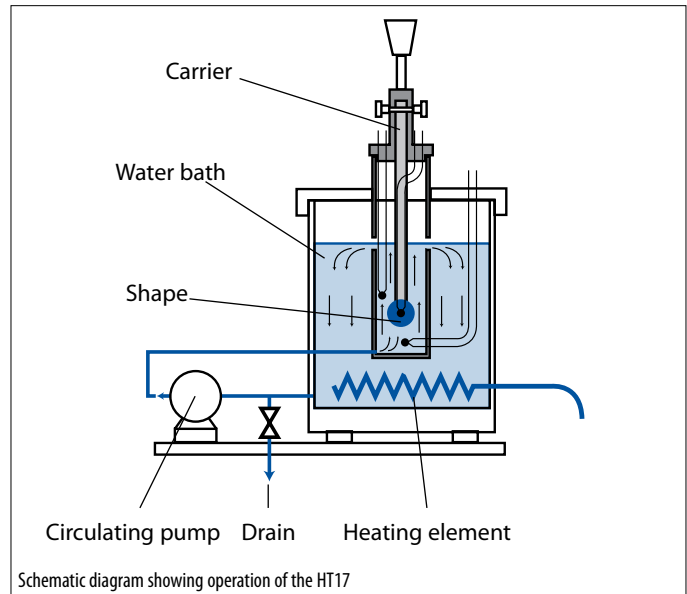

A circulating pump mounted alongside the water bath draws water from the bath and returns it at the base of a vertical cylindrical duct which is located inside the water bath at the centre.

A holder ensures that each of the shapes is quickly and correctly positioned within the vertical duct for measurements to be taken.

The upward flow of water at constant velocity past the shape ensures that the heat transfer characteristic remains constant and also ensures that the water surrounding the shape remains at a constant temperature. The rate of water recirculation can be varied by using the HT10XC to adjust the dc voltage on the pump.

The shape holder has been carefully designed to eliminate the need to touch the shape while its temperature stabilises in air and also to position the shape accurately inside the water bath while transient measurements are taken.

A thermocouple mounted on the shape holder contacts the hot water at the same instant as the solid shape and provides an accurate datum for temperature/time measurements.

A thermostat allows the water to be heated to a predetermined temperature before taking measurements. The large volume of water in the bath ensures that any change in the temperature of the water, as the measurements are taken, is minimal.

The water bath is heated by a mains powered electrical heater, and protected by a Residual Current Device for operator safety. A thermocouple located in the water bath enable the temperature of the water to be monitored and adjusted to the required temperature.

EXPERIMENTAL CAPABILITIES

Bodies of different size, shape and material are allowed to stabilise at room temperature then dropped into the hot water bath.

The change in temperature of each body is monitored. Analytical temperature/heat flow charts are used to analyse the results obtained from different solid shapes. The results obtained from one shape can be used to determine the conductivity of a similar shape constructed from a different material.

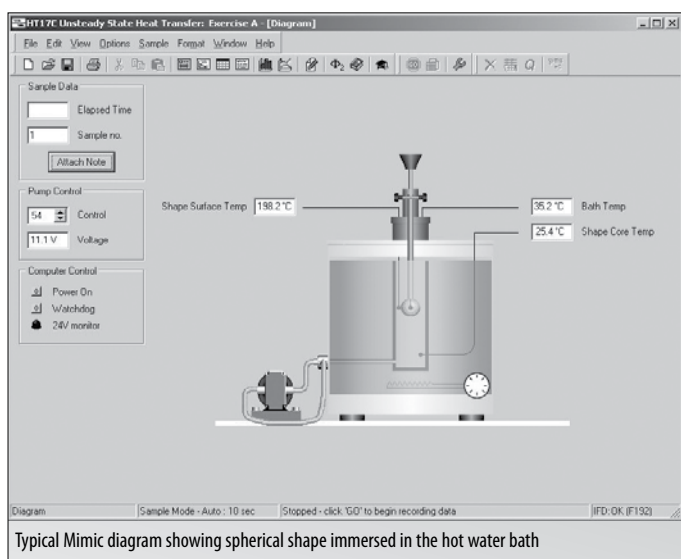

Typical Mimic diagram showing spherical shape immersed in the hot water bath



Shape holder and solid shapes supplied with HT17

ESSENTIAL ACCESSORIES

HT10XC Computer Controlled Heat Transfer Service Unit with associated PC for data logging.

REQUIREMENTS

Electrical supply:

HT17-A: 230V/1ph/50Hz @ 13 Amp

HT17-B: 115V/1ph/60Hz @ 26 Amp

HT17-G: 230V/1ph/60Hz @ 13 Amp

OVERALL DIMENSIONS

Height: 0.67m

Width: 0.60m

Depth: 0.40m

SHIPPING SPECIFICATION

Volume: 0.17m³

Gross Weight: 14kg

ORDERING SPECIFICATION

UNSTEADY STATE HEAT TRANSFER - HT17

- A small scale accessory designed to enable exercises to be performed in unsteady state heat transfer.
- Comprises an electrically heated water bath, variable speed recirculation pump, a set of solid thermal shapes and a shape holder.
- The shapes supplied comprise a rectangular slab, a long cylinder and a sphere, Two of each shape are supplied, manufactured from both brass and stainless steel. Each shape is instrumented with a thermocouple to monitor the temperature at the centre of the shape.
- Analytical transient-temperature/heat flow charts are supplied for each of the shapes.
- The water bath heater is 3kW. The water bath includes an integral flow duct and a thermocouple to measure the water temperature.
- The circulating pump ensures that hot water flows past the solid shape under evaluation at constant velocity during the test. It is a variable speed dc pump.
- The accessory is mounted on a PVC baseplate, which is designed to stand on the bench top and connect to the Heat Transfer Service Unit without the need for tools.
- A comprehensive instruction manual is included.

THERMO-ELECTRIC HEAT PUMP - HT18C

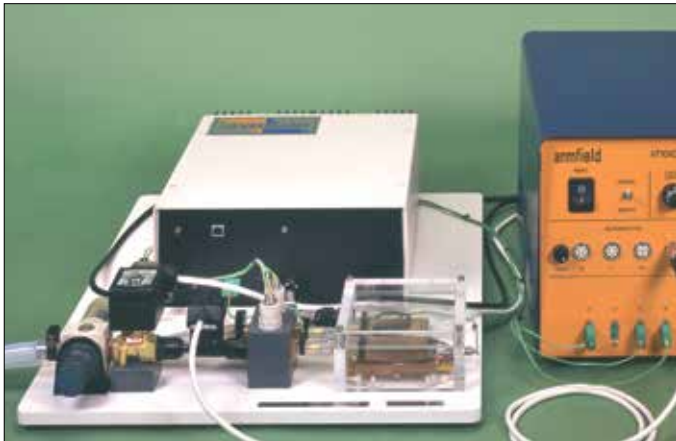

Thermo-Electric Heat Pump - HT18C

Based on a Peltier device, the Armfield HT18C Thermo-electric Heat Pump demonstrates how electrical power can be used to extract heat from a cool surface and transfer it to a hot surface. This effect is becoming widely used for point cooling (e.g. of semiconductor devices) and small scale volumetric cooling.

The HT18C is designed for use with the Armfield HT10XC Heat Transfer Teaching Equipment.

TECHNICAL DETAILS

The thermo-electric Peltier device is positioned in a heat transfer path, between two copper blocks, extracts heat from one block (cold reservoir) and transfers it to the other block (hot reservoir). In order to measure the heat transfer rate, the cold reservoir is fitted with an electric heater, powered by the HT10XC. By varying the electric power into the system, the behaviour of the system at different operating points and temperatures can be established.

The heat extracted is transferred to the hot reservoir, together with heat generated by the electrical supply to the peltier device. This heat is removed by a water-cooled heat exchanger. The flow rates can be adjusted to provide a range of operating temperatures.

The Peltier device can also be used to generate a small quantity of electric power when a temperature difference is applied. This effect can also be demonstrated with the HT18C.

Instrumentation is provided to measure the temperatures of the blocks, the electric power supplied to the Peltier device, the cooling water flow rate and the cooling water temperature rise. The heater power is measured by the HT10XC, and so it is possible to establish a complete energy balance for the system.

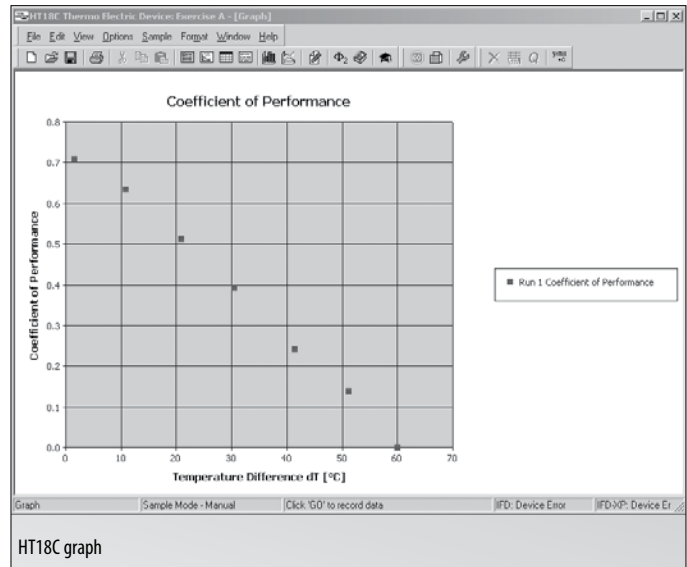

All facilities are controlled directly from the computer, including heater power, Peltier power and water flow rate. All measured information is available for display and recording on the computer. The HT18C includes its own integral USB interface, which connects to the same computer as the HT10XC. The software supplied integrates the data to and from both these interfaces into a simple, user friendly software control environment. The HT18C derives its power from the HT10XC, and so is protected by the same safety features when used in remote configuration.

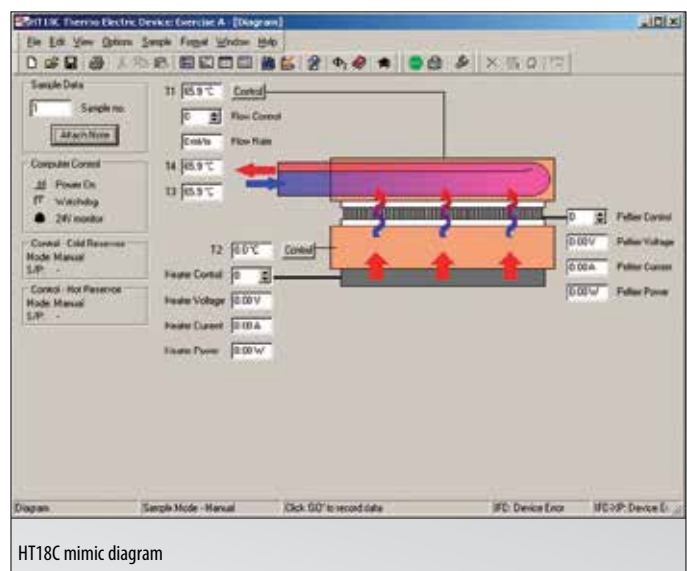

EXPERIMENTAL CAPABILITIES

- Performance of a Peltier device as a cooler
- > Heat transfer characteristics as a function of temperature and drive current
 - > Measurement of the co-efficient of performance
 - > Energy balance
 - > Demonstration of a Peltier device as an electrical generator

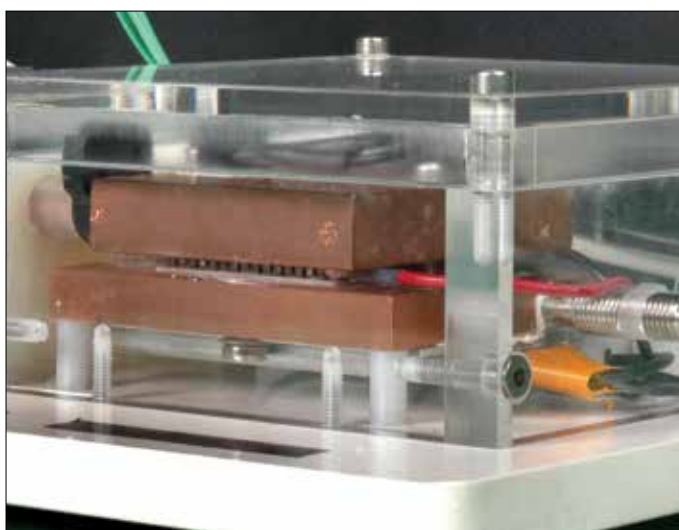

Detail showing the thermo-electric Peltier device of the HT18C

ESSENTIAL ACCESSORIES

Requires HT10XC Heat Transfer Service Unit and a PC running Windows 98 or above, with two available USB interfaces.

REQUIREMENTS

Cold Water Supply:

1.5 litres/minute @ 1barg

Electrical supply:

All electrical requirements are obtained from the HT10XC service unit

NOTE: the supply rating of the HT18C must be the same as the HT10XC that it is used with, i.e.

HT18C-A: 230V/1ph/50Hz

HT18C-B: 115V/1ph/60Hz

HT18C-G: 230V/1ph/60Hz

OVERALL DIMENSIONS

Height: 0.13m

Width: 0.43m

Depth: 0.53m

SHIPPING SPECIFICATION

Volume: 0.07m³

Gross Weight: 15kg

ORDERING SPECIFICATION

THERMO-ELECTRIC HEAT PUMP - HT18C

- Small scale accessory designed to demonstrate the use of a Peltier device to transfer heat across surfaces
- Comprises a Peltier device, a heater, and a water-cooled heat exchanger
- Heat transfer rates up to 68 Watt
- Heater power, Peltier drive and cooling flow rate all fully electronically adjustable under computer control.
- Measurement of cooling water temperatures and flow to allow an overall energy balance
- The accessory is mounted on a PVC baseplate, which is designed to stand on a bench and connect to the heat transfer service unit without the need for tools.
- A comprehensive instruction manual is provided
- Software is provided.

FREE AND FORCED CONVECTION - HT19

The Armfield Free and Forced Convection unit has been specifically designed to demonstrate the phenomena of natural (free) and forced convection. Temperature profiles and heat flux over three different heat transfer surfaces can be easily studied.

The HT19 is designed for use with the Armfield HT10XC Heat Transfer Teaching Equipment.

UNIQUE FEATURES

- > Transparent duct allows visualisation of the whole process
- > Experiments can be performed outside the duct to give totally free convection
- > The heated surfaces can also be operated on the bench to investigate the effects of orientation (guards provide safety)
- > Simple interchange of heat exchangers (all incorporate their own heaters)
- > Results can be compared directly to theory
- > Powerful Armsoft software, with separate exercises for each configuration

TECHNICAL DETAILS

This unit consists of a bench mounted vertical air duct positioned on the top of a centrifugal fan. The air duct incorporates an aperture positioned at the rear wall of the duct, into which three different types of heat transfer surfaces can be inserted. The three types of heat exchanger supplied are; flat plate, cylindrical pins and finned surface.

The unit incorporates an electrical heating element, with positive thermal cut-out, and thermocouples for precise temperature measurement. The clamping mechanism ensures accurate alignment of the surface inside the duct. The front wall of the duct is acrylic, to allow viewing of the heated surface and measurement sensors.

For forced convection, the centrifugal fan draws ambient air upwards through a flow straightener and over the heated surface (A manually variable throttle controls the airflow).

An air velocity sensor measures the air velocity inside the duct upstream of the heat exchanger.

Thermocouples measure the air temperature before and after the heated surface, together with the surface temperature at three positions along the extended surface exchangers.

On the HT19 the heater power, the air flow rate and the configuration of the heated surfaces can all be controlled via the HT10XC, either from the front panel controls or from the software.



Free and Forced Convection - HT19 shown with finned surface

EXPERIMENTAL CAPABILITIES

- > Relationship between surface temperature and power input in free convection
- > Relationship between surface temperature and power input in forced convection
- > Understanding of the use of extended surfaces to improve heat transfer from the surface
- > Determining the temperature distribution along an extended surface
- > Comparing characteristics of a vertical and horizontal flat plate in free convection
- > Determining the characteristic velocity, the Reynolds, Grashof and Rayleigh numbers for a flat plate in free convection
- > Calculation of the average heat transfer coefficient of the pinned heater in Forced convection
- > Comparing horizontal and vertical configurations for a finned exchanger in free convection

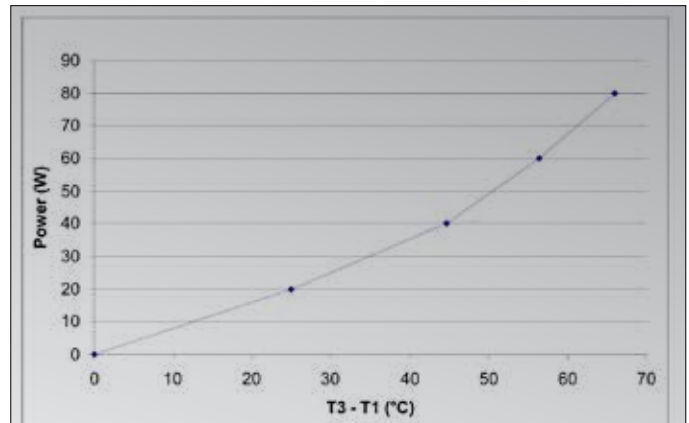

Typical graph of power against surface temperature for finned surface

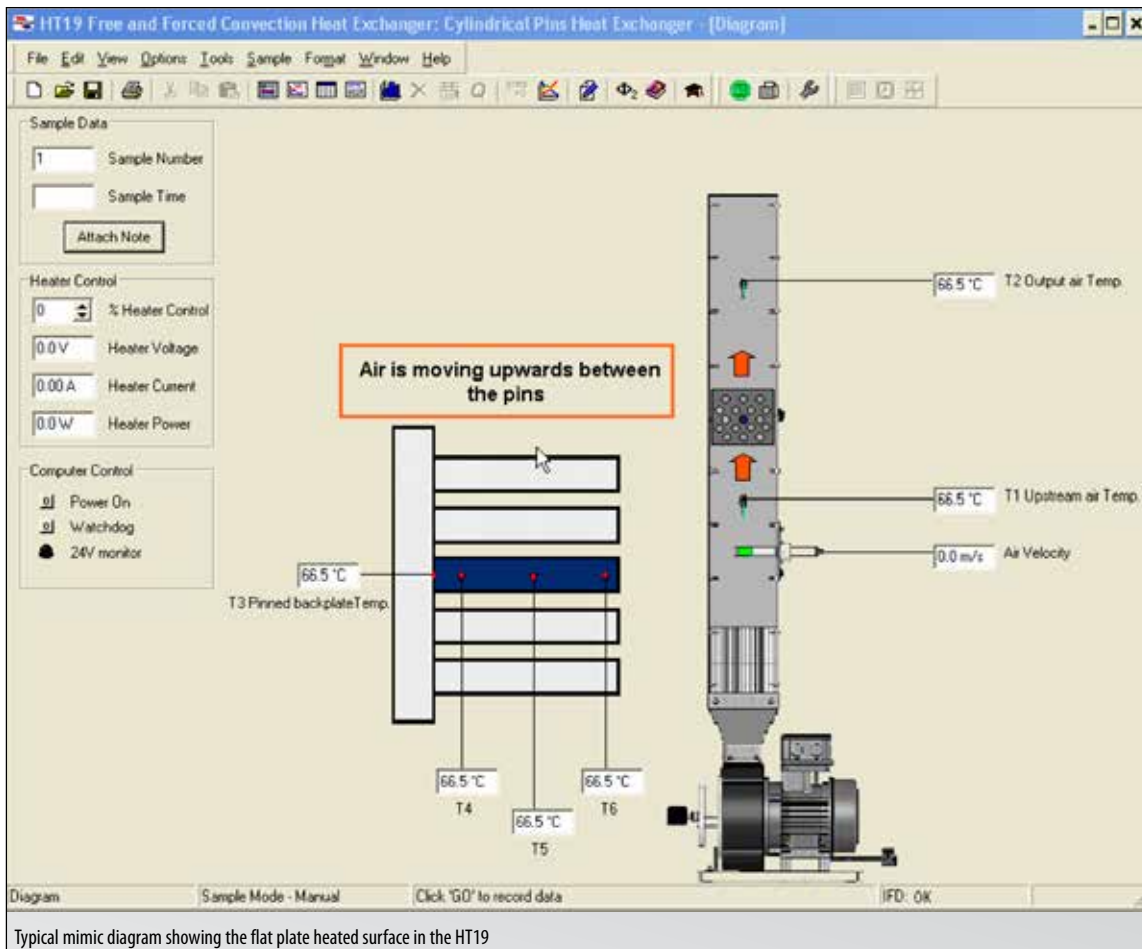

Typical mimic diagram showing the flat plate heated surface in the HT19

FREE AND FORCED CONVECTION - HT19 - CONTINUED



Flat plate surface



Cylindrical pin surface

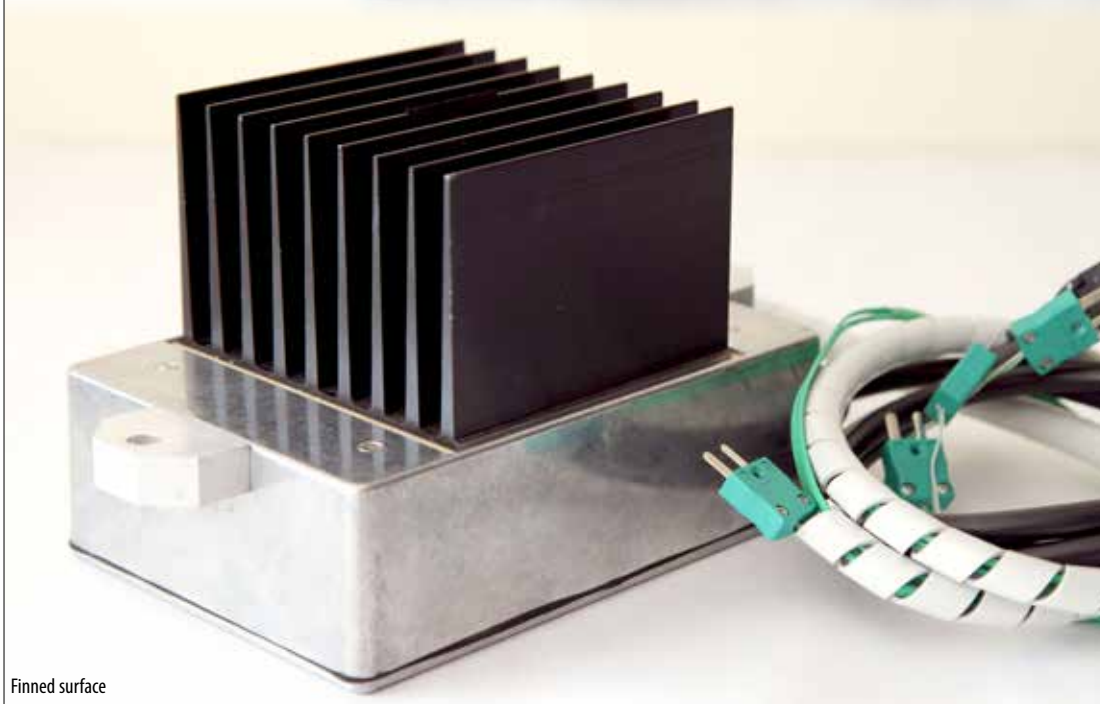

Finned surface

ESSENTIAL EQUIPMENT

HT10XC Computer Controlled Heat Transfer Unit.

REQUIREMENTS

Electrical supply:

All electrical requirements are obtained from the service unit.

NOTE: the supply rating of the HT19 must be the same as that of the HT10X/HT10XC that it is used with, i.e.

HT19-A: 230V/1ph/50Hz
HT19-B: 115V/1ph/60Hz
HT19-G: 230V/1ph/60Hz

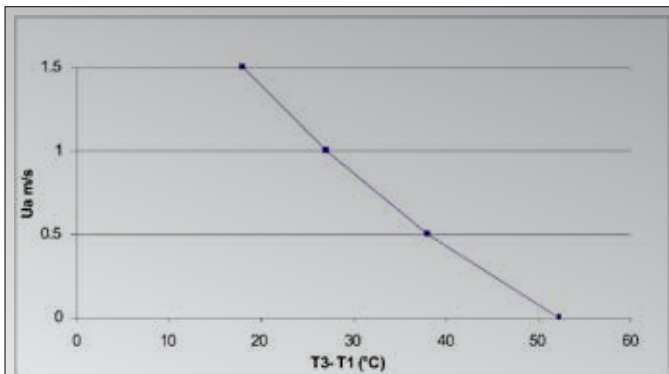

Typical graph of air velocity against surface temperature for the finned surface

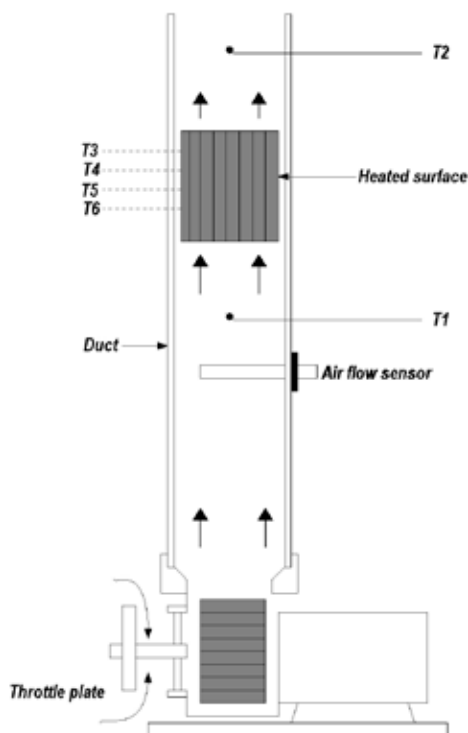

Schematic diagram - HT19

OVERALL DIMENSIONS - HT19

Height: 0.95m
Width: 0.30m
Depth: 0.35m

SHIPPING SPECIFICATION - HT19

Volume: 0.1m³
Gross Weight: 12kg

ORDERING SPECIFICATION - HT19

- A bench mounted unit specifically designed to demonstrate the phenomena of free and forced convection and to measure temperature profiles from three different heat transfer surfaces
- Comprises of a vertical air duct, with a transparent front for visibility mounted on a fan at the base of the duct, three heat transfer surfaces, airflow, and temperature probes
- Technical data is included for each of the three heat transfer surfaces, which will enable students and researchers to compare practical results with theoretical analysis for free and forced convection
- Three heat transfer surfaces supplied: a flat plate surface area 0.011m², pinned extended surface area 0.0525m², and finned extended surface area 0.1414m²
- Vertical duct incorporates a transparent front wall allowing complete visualisation of the process and identification of the airflow and temperature sensors
- Each heat transfer surface is fitted with its own heater (240W) and thermocouples, to enable easy interchange
- All heat transfer surfaces incorporate guards to permit safe use outside of the duct for performing free convection experiments
- ArmSoft software for HT19 includes separate exercises for each of the heat transfer surfaces in free or forced convection and records of all measured variables for analysis and comparison of the performances
- K-type thermocouples measure the air temperature in the duct before and after the heater as well as the surface temperature of the heat transfer surfaces
- The airflow is manually adjustable up to 10m/s
- The airflow is measured by an air velocity sensor, which is inserted inside the duct
- The HT19 is mounted on a PVC baseplate which is designed to stand on the bench top and connect to the HT10XC with simple pug in connections
- A comprehensive instruction manual is included

OTHER PRODUCTS IN THE HEAT TRANSFER RANGE INCLUDE:

HT30XC COMPUTER CONTROLLED HEAT EXCHANGER SERVICE MODULE

Remote operation capability

Computer controlled heat exchange service unit, with a range of six interchangeable heat exchangers.

All operational functions, including control of co- and counter-flow are now under computer control, and safety functions implemented to shut down the system in case of software or communication breakdown.



THERMODYNAMICS - TH SERIES

Extends the study of heat into the field of Thermodynamics

The TH range is designed to introduce the fundamental principles of thermodynamics to enable the student to gain an understanding of these difficult concepts.

TH1: Temperature Measurement and Calibration

NOW WITH BOYLES LAW TH2: Pressure Measurement and Calibration

MARCEC BOILER TH3: Saturation Pressure

TH4: Recycle Loops

TH5: Expansion Processes of a Perfect Gas



Armsoft 306 - 64/32-bit Windows compatible software

FOR FURTHER INFORMATION ON THE ADVANCED FEATURES OF THE SOPHISTICATED ARMFIELD SOFTWARE VISIT:
www.discoverarmfield.co.uk/data/armsoft



ArmSoft™



Head Office:
Armfield Limited
Bridge House, West Street,
Ringwood, Hampshire.
BH24 1DY England

Telephone: +44 1425 478781
Fax: +44 1425 470916
E-mail: sales@armfield.co.uk

U.S. Office:
Armfield Inc.
9 Trenton - Lakewood Road
Clarksburg NJ 08510
Tel/Fax: (609) 208-2800
E-mail: info@armfieldinc.com

Scan QR code* to visit our website

* Scan with smartphone with QR code scanning software installed.



An ISO 9001 Company

Innovators in Engineering Teaching Equipment

learn more! www.armfield.co.uk

© 2012 Armfield Ltd. All Rights Reserved
We reserve the right to amend these specifications without prior notice. E&OE 0912/3k/SO 2995
* Correct at time of going to press.



Find us on YouTube!
www.youtube.com/user/armfieldUK
Follow us on Twitter, Facebook,
LinkedIn and
WordPress

