

Armfield is proud to present two new ANAEROBIC REACTORS.

These units can be operated in different configurations making them extremely versatile and suitable for both educational and research purposes.



BE4 Anaerobic Tank Reactor

(shown with optional Settler BE4-1)

- Continuous Stirred Tank Reactor (CSTR)
- Packed Bed Reactor (PBR)
- Upflow Anaerobic Sludge Blanket Reactor (UASB)



BE3 Anaerobic Column Reactor:

- Fluidised Bed
- Expanded Granular Sludge Bed Reactor (EGSB)

FEATURES

- > Simple change of reactor configurations
- > The reactors are made of glass so the contents are fully visible
- > Accurate control of temperature to suit the bacteria
- > Provision for sampling of liquids and gases
- > Automatic pH control with two dosing pumps
- > Accurate and highly visual measurement of gas produced
- > Provision for fitting user supplied instrumentation
- > Very low back pressure on reactor from gas collector
- > Data logging system with software
- > Optional settling tank for BE4



BE3 ANAEROBIC COLUMN REACTOR



DESCRIPTION - BE3 ANAEROBIC COLUMN REACTOR

The Anaerobic Column Reactor BE3 features a tall, slender, cylindrical glass column in two sections, each section with a heating jacket. At the top of the column, a third unheated section collects the gas and provides an effluent overflow. Between the two heated sections is a manifold, which provides ports for instrumentation, sampling and dosing. The feed into the reactor is provided by a variable speed peristaltic pump.

The temperature of the column contents can be controlled by circulating warm water through the jackets of the lower two sections. The water is heated in a heating tank, using an electric heater and distributed by a recirculation pump using PID control. Typically the reactor temperature is set to 35°C to suit the anaerobic bacteria in the feedstock.

The column contents can be recirculated from the top section to the bottom section using a variable speed pump. The recirculation can also be used to fluidise a bed of media (e.g. pumice) used to support the growth of biomass. Alternatively the column can be operated as an Expanded Granular Sludge Bed Reactor (EGSB) with no media filling.

A novel feature of the new Anaerobic Reactors is the gas collection system. This enables the rate of gas emission

to be accurately measured over long periods of time. This occurs even when very low quantities of gas are produced, while retaining low back pressure in the system so as not to inhibit the release of the gasses. It operates by collecting a known volume of gas over water. When the collection tank is full the gas is automatically discharged and the water replaced. The PLC counts the number of cycles to measure the total volume of gas, and measures the time between discharges to calculate the flow rate.

The reactor is supplied complete with a pH dosing system. This comprises two peristaltic pumps under control of the PLC, used to add a base solution or an acid solution to the reactor as appropriate. The user can define the range of pH values to be maintained.

Storage positions are provided for standard five litre chemical jars, enabling the dosing solutions to be prepared in advance and left in place throughout the process, minimising the need to handle potentially harmful chemicals.

As well as the gas collection rate and volume, further instrumentation measures the reactor temperature, pH, water temperature and the recirculation flow. This data can all be recorded on a PC using the data logger.

BE3 schematic

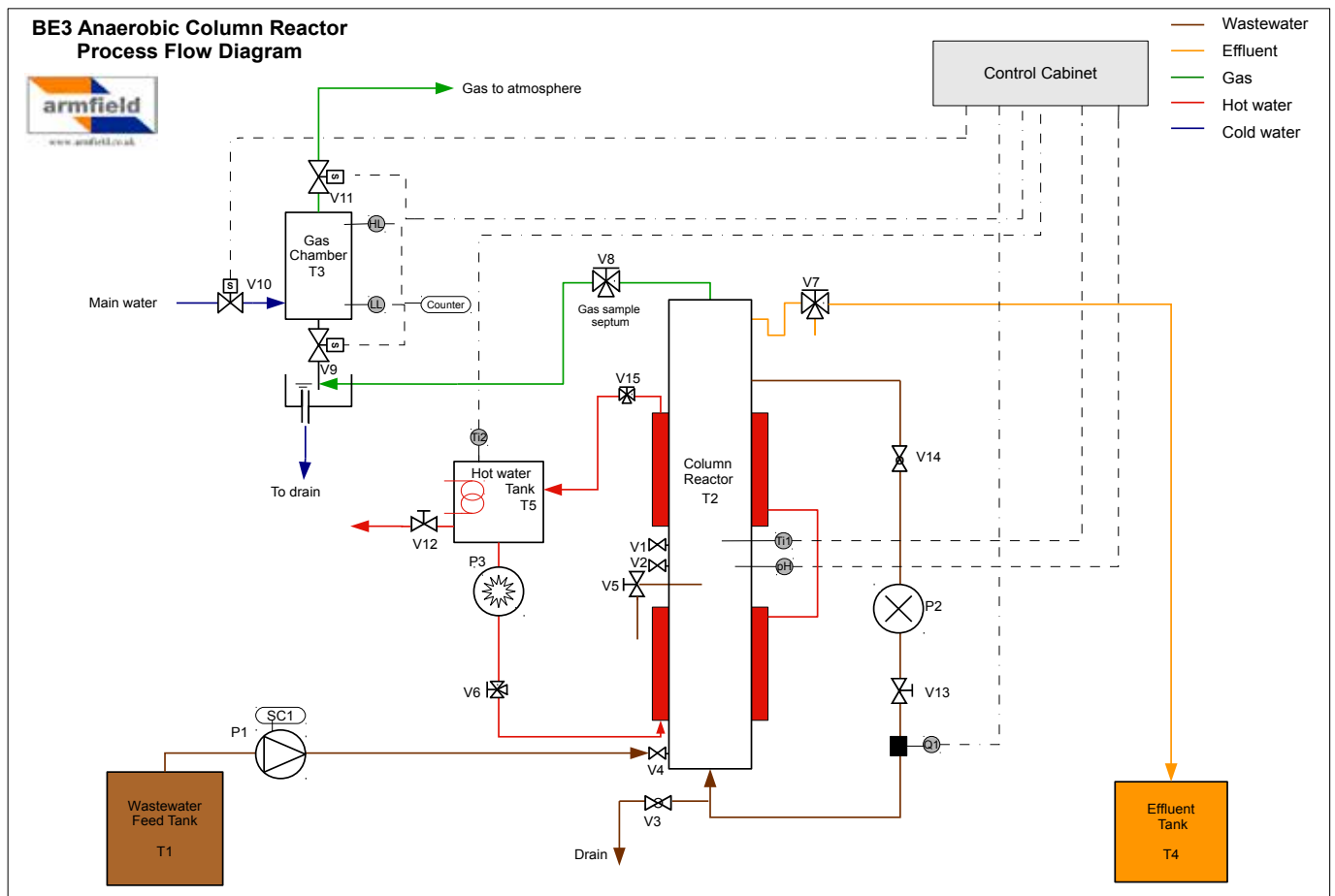

BE4 ANAEROBIC TANK REACTOR



BE4 shown with optional Settler Reactor BE4-1

DESCRIPTION - BE4 ANAEROBIC TANK REACTOR

The reactor on BE4 is a cylindrical glass vessel with a water jacket for heating. The vessel is supplied with baffles and a variable speed stirrer for use as a Continuous Stirred Tank Reactor (CSTR).

The baffles and stirrer are removable to enable the reactor to be filled with Bioballs and a support grill, to reconfigure the unit as a Packed Bed Reactor.

An alternative reactor lid complete with deflector and tri-phase separator is also supplied. This enables the reactor to also be configured as an Upflow Anaerobic Sludge Blanket Reactor (UASB).

The feed into the reactor is provided by a variable speed peristaltic pump. The lid of the reactor is fitted with a sampling station, which includes ports for instrumentation probes (both temperature and pH) and permits liquid samples to be taken from the reactor at different depths.

The reactor temperature is controlled by a recirculating water system in the same way as the BE3 and the same novel system for collecting and measuring the emitted gas is used. Similarly the pH dosing system is identical in concept and the data can be recorded on a PC using the datalogger.

Settler Reactor BE4-1

An optional Settler (BE4-1) is also available for the Anaerobic Tank Reactor BE4. Its function is to collect solid particles of biomass at the exit from the reactor for return to the reactor in BE4. This biomass would otherwise be lost to the system.



BE4-1 Settler

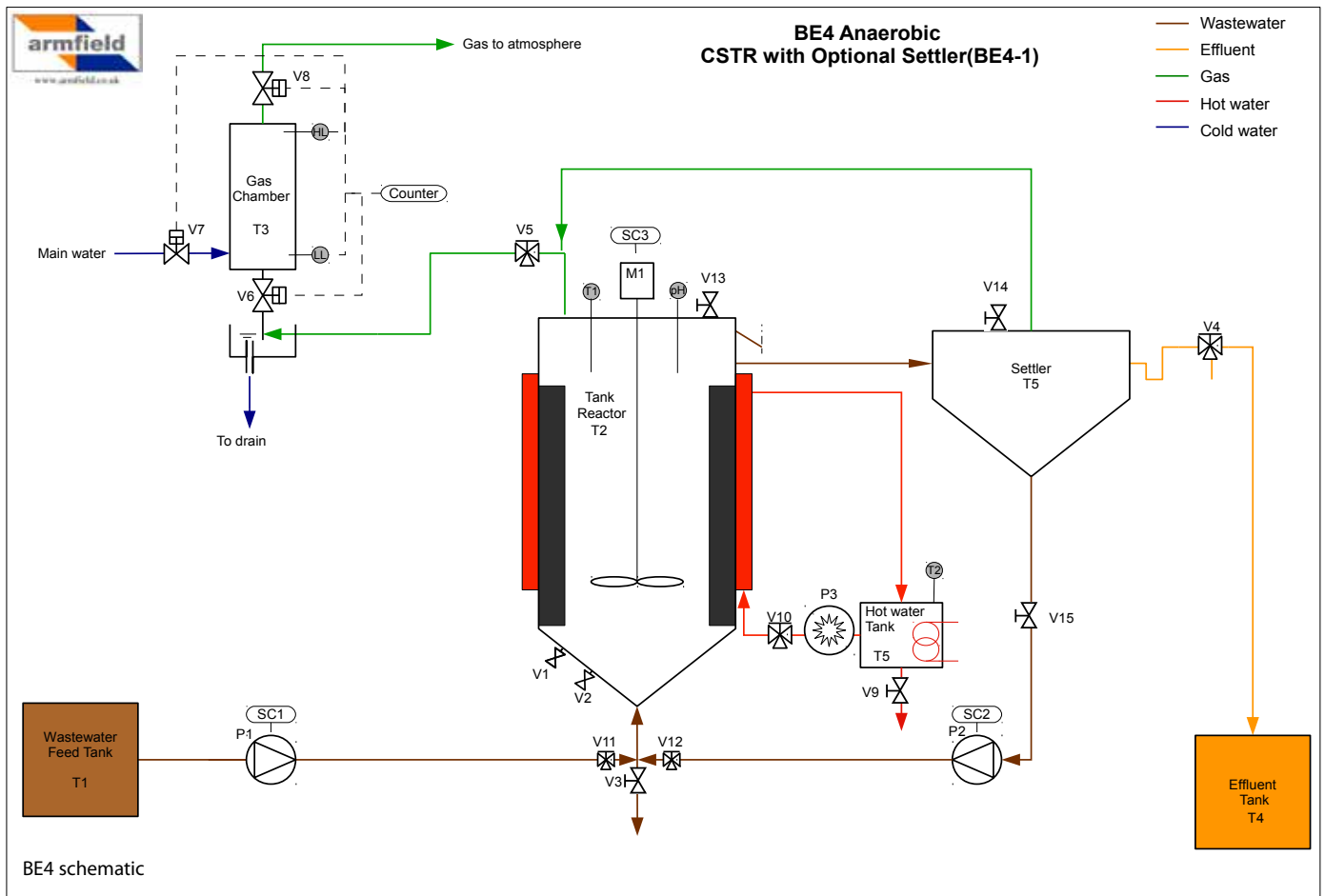

BE4 ANAEROBIC TANK REACTOR



Tank Reactor showing detail of baffles, deflector and lid configured as UASB (Upflow Anaerobic Sludge Blanket Reactor)



Tank Reactor showing detail of bio-balls and supports, configured as PBR (Packed Bed Reactor)



BE4 configured as CSTR (Continuous Stirred Tank Reactor)

OPERATION

Typically the reactors would be started up by using a suitable starter culture.

EXPERIMENTAL CAPABILITIES

- Optimising reactor start up (acclimation of biomass)
- Effect of temperature, pH, residence time etc
- Investigation of hydraulic loading (feed rate)
- Effect of effluent strength and nutrient deficiency
- Effect of recirculation ratio and fluidisation
- Comparing efficiency of different configurations (BE4)
- Investigation of bacteria type
- Acidogenesis and Methanogenesis process demonstrations

SPECIFICATIONS

	BE3	BE4
Reactor volume	9 l	20 l
Heater power	2 kW	2 kW
Jacket temperature	< 60°C	< 60°C
Flow rate (Recycle)	15 l/min	55 l/hr
Feed flow rate	0.06 to 4.81 l/hr	0.06 to 4.81 l/hr
Settler volume	N/A	11 l (BE4-1)

REQUIREMENTS

Electricity

BE3-A 220-240V/1ph/50Hz, 10A
BE3-G 220-240V/1ph/60Hz, 10A
BE4-A 220-240V/1ph/50Hz, 10A
BE4-G 220-240V/1ph/60Hz, 10A

Water and Drain

The reactors need to be connected to a supply of water (>1 bar) and to a suitable drain. The amount of fresh water used during the operation of the BE3/BE4 will be the same as that of the gas produced.

Ventilation

The gas produced can be collected (vessel not provided) or can be vented to atmosphere. In any case the reactors should be positioned in a well ventilated area, and an outlet provided to vent the emitted gasses outdoors.

Computer

A Windows PC (not supplied) running Windows 98 or later, with USB port is required if running the data logging software.

ORDERING SPECIFICATIONS

BE3 Specific

- A self-contained, floor-standing anaerobic column reactor, nine litre volume
- Configurable as a Fluidised Bed Reactor and an Expanded Granular Sludge Bed Reactor (EGSB)
- Split heated column with central collar for instrumentation, dosing and liquid sampling
- Recycle pump capable of rates from 0 – 15 l/min
- Electronic measurement of recycle rate

BE4 Specific

- A self-contained, floor-standing anaerobic tank reactor, volume 20 litres
- Configurable as:
 - Continuous Stirred Tank Reactor (CSTR)
 - Packed Bed Reactor (PBR)
 - Upflow Anaerobic Sludge Blanket Reactor (UASB)
- Stirrer, motor and baffles are removable for non-stirred configurations
- Variable depth liquid sampling point

Common Points to BE3 and BE4

- Measures reactor temperature, jacket temperature and vessel pH
- Programmable logic controller (PLC) provides temperature control, pH control and gas collection (rate and totalisation) calculations
- Jacket heating system with pump and hot water vessel. Temperature is PID controlled room temperature to 55°C.
- Automated volumetric gas collection system measures, which adds less than 10 mbar back pressure to the reactor.
- Complete with automated pH dosing system to maintain the vessel pH within a predetermined range (user programmable)
- User calibration of pH and gas collection system
- Feed flow rates from 0.06 to 4.8 l/hr (using interchangeable peristaltic hoses)
- Gas sample point
- Data logger and software as standard

OVERALL DIMENSIONS

	BE3	BE4
Height:	1.797m	1.500m
Width:	1.038m	0.738m
Depth:	0.715m	0.696m

SHIPPING SPECIFICATION

	BE3	BE4
Volume:	2.0m ³	1.5m ³
Gross weight:	220kg	150kg

COMPLEMENTARY EQUIPMENT

BE1 Batch Enzyme Reactor
 BE2 Chromatography Unit
 UOP12 Filtration Unit
 W8 Anaerobic Digester
 W11 Aerobic Digester

BE3 Specific

- A self-contained, floor-standing anaerobic column reactor, nine litre volume
- Configurable as a Fluidised Bed Reactor and an Expanded Granular Sludge Bed Reactor (EGSB)
- Split heated column with central collar for instrumentation, dosing and liquid sampling
- Recycle pump capable of rates from 0 – 15 l/min
- Electronic measurement of recycle rate

BE4 Specific

- A self-contained, floor-standing anaerobic tank reactor, volume 20 litres
- Configurable as:
 - Continuous Stirred Tank Reactor (CSTR)
 - Packed Bed Reactor (PBR)
 - Upflow Anaerobic Sludge Blanket Reactor (UASB)
- Stirrer, motor and baffles are removable for non-stirred configurations
- Variable depth liquid sampling point

Common Points to BE3 and BE4

- Measures reactor temperature, jacket temperature and vessel pH
- Programmable logic controller (PLC) provides temperature control, pH control and gas collection (rate and totalisation) calculations
- Jacket heating system with pump and hot water vessel. Temperature is PID controlled room temperature to 55°C.
- Automated volumetric gas collection system measures, which adds less than 10 mbar back pressure to the reactor.
- Complete with automated pH dosing system to maintain the vessel pH within a predetermined range (user programmable)
- User calibration of pH and gas collection system
- Feed flow rates from 0.06 to 4.8 l/hr (using interchangeable peristaltic hoses)
- Gas sample point
- Data logger and software as standard (requires PC, not supplied)



* Excluding D/M arrange



Find us on YouTube!
www.youtube.com/user/armfieldUK
 Follow us on Twitter, Facebook,
 LinkedIn and
 WordPress



Head Office:
 Armfield Limited
 Bridge House, West Street,
 Ringwood, Hampshire.
 BH24 1DY England

Telephone: +44 1425 478781
 Fax: +44 1425 470916
 E-mail: sales@armfield.co.uk

U.S. Office:
 Armfield Inc.
 9 Trenton - Lakewood Road
 Clarksburg NJ 08510
 Tel/Fax: (609) 208-2800
 E-mail: info@armfieldinc.com

© 2015 Armfield Ltd. All Rights Reserved
 We reserve the right to amend these specifications without prior notice. E&OE 03/14/3k
 Correct at time of going to press.

Scan QR code* to visit our website

* Scan with smartphone with
 QR code scanning software installed.



An ISO 9001 Company

Innovators in Engineering Teaching Equipment

learn more! www.armfield.co.uk